

Electrical safety costs little – a human life is priceless



Design the
future of energy



Bender – Electrical safety in hospitals

The benefits offered by modern medical knowledge and technical equipment are overruled by unexpected loss of electrical power. In certain medical rooms like ICU, OT, time is of the essence and the absolute reliability of electrical systems is of vital importance.

Safe and secure electrical power systems

Bender systems have provided the answer for reliable and cost effective electrical safety solutions for healthcare facilities for over 70 years. Hospitals around the world rely on Bender products and the technical support of Bender engineers, where the safety of patients and the critical performance of their medical electrical equipment is at stake.



Bender – Your partner in the application of the new international standard for electrical safety in hospitals

Bender is acknowledged as the expert in the design and installation of power systems according to the latest international standard IEC 60364-7-710: Electrical installations of buildings – Requirements for special installations or locations – medical locations. Bender systems are specially developed for electrical safety management in health care facilities. They provide early detection of critical errors or insulation deteriorations in electrical systems and of medical electrical equipment.

Principles for an electrical safety management in healthcare facilities

- Insulation faults must not lead to a power failure.
- Fault currents in an electrical system must be reduced to an uncritical level.
- Permanent monitoring of the power supply for medical locations must be guaranteed.
- Fault repairs must be able to be planned in advance to suit patient needs and maintenance purposes.
- The provision of clear unambiguous labelling of power outlets and distribution switchboards with readily available system documentation.

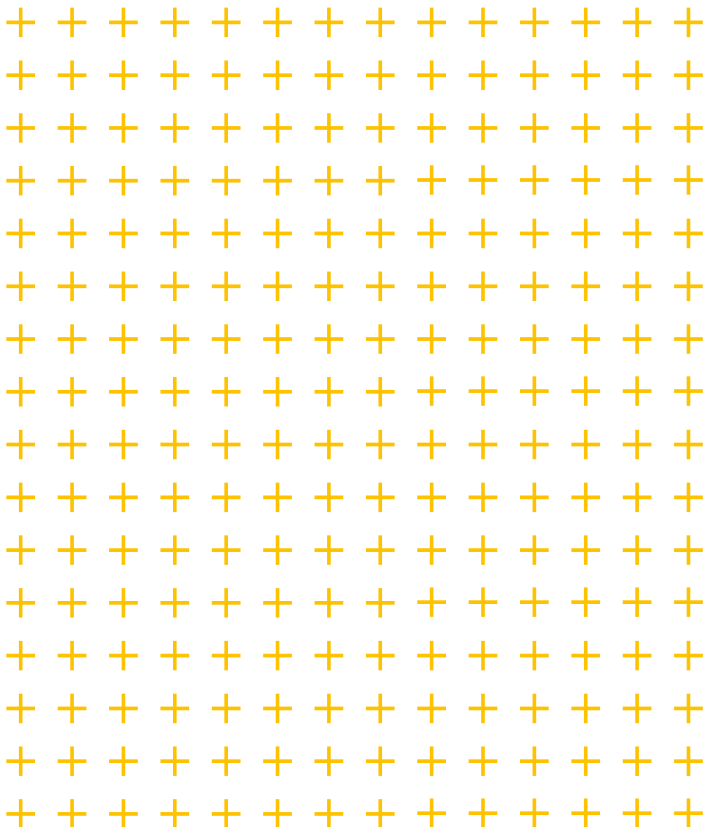

Optimal electrical safety

Whoever takes responsibility for the building or running of a hospital or any other healthcare facility has to ensure a maximum of electrical safety. Bender is a reliable partner worldwide developing the appropriate system solution in accordance with the international standard IEC 60364- 7-710 HD 60364-7-710.

As there can be no compromise concerning the safety of patients and staff, we create flexible solutions for your needs. Let us be your partner and take advantage from our expert knowledge

...in the design stage

- Professional advice
- Design support
- Drafting of invitation to tender

...during the installation

- Installation of devices and systems
- Functional test and commissioning
- Fault location/fault clearance
- Adaptation/optimisation
- Operator training

...and later on

- Support
- Inspection/maintenance
- Repair/spares
- Retro-fitting, modifications, extensions

Content

Bender – Electrical safety in hospitals is vital	2	MK2430	Remote alarm indicator and test combination	28
A.		LINETRAXX® CMS460-D4-2	Three phase loads monitoring	30
Which power supply system ensures maximum safety?	6	COMTRAXX®	The turnkey solution from Bender	32
IT systems (unearthed systems) – for a reliable power supply	7	Flexible and individual solutions		33
Insulation monitoring – safety plus thanks to advance information	8	ATICS®	Transfer switching and monitoring devices	34
B.		IT System Distribution Boards for Operating Theatre and Intensive Care		36
How do you avoid dangerous overloads?	10	EDS151	Insulation fault location system	38
C.		Power supply units		39
How do you inform your staff?	11	EDS441	Insulation fault location system	40
D.		Wiring diagram	Insulation fault location system	42
How do you avoid dangers in case of public electricity supply failure?	12	ES710	Single-phase isolating transformer	44
E.		DS0107	Three-phase isolating transformer	46
What else can you do for increased safety? Insulation fault location for critical rooms	14	LINETRAXX® Power Quality and Energy Measurement	For transparency in electrical installations	48
What else can you do for increased safety? Residual current monitoring for TN-S systems	16	Bender communication solutions		50
The complete solutions	18	Bender service		52
ISOMETER® IR427 + MK7		Bender. Make your world safe		53
Insulation-, load- and temperature monitoring device	20	References		54
ISOMETER® isoMED427P				
Insulation-, load- and temperature monitoring device	22			
ISOMETER® IR426-D47				
Insulation monitoring device for operating theatre lamps	24			
COMTRAXX® CP305				
Remote alarm indicator for medical locations and other areas	26			



We want to inform you about the five most important topics concerning electrical safety in healthcare facilities as follows:

A

Which power supply system ensures maximum safety?

B

How do you avoid dangerous overloads?

C

How do you inform your staff?

D

How do you avoid dangers in case of public electricity supply failure?

E

What else can you do for increased safety?

A

Which power supply system ensures maximum safety?

Safety standards in medical locations

According to IEC 60364-7-710, the medical procedures carried out in a room, define the group classifications of medical locations.

Group 0

Medical location where ME equipment or ME systems are not intended to be used.

Group 1

Medical location where ME equipment or ME systems are intended to be used externally or invasively on any part of the patient and where discontinuity of the electrical supply, such as protection against electric shock, does not represent a risk to the safety of the patient.

Group 2

medical location where ME equipment or ME systems are intended to be used intrusively, externally or invasively to any part of the patient and where discontinuity of the electrical supply, such as protection against electric shock, represents a risk to the safety of the patient

The highest demands are made in Group 2 medical locations

A first fault must not result in power supply interruption and hence to failure of life-support equipment. IEC 60364-7-710 requires the IT system (unearthed system) for all Group 2 medical locations

710.411.6.1.101

In Group 2 medical locations, the medical IT system shall be used for:

- Circuits supplying medical electrical equipment and systems intended for life-support or surgical applications
- Other technical equipment in the patient environment

The following rooms are of special concern:

- Anaesthetic rooms
- Operating theatres
- Operating preparation rooms
- Operating recovery rooms
- Heart catheterization rooms
- Intensive care rooms
- Angiographic examination rooms
- Premature baby rooms



A

IT systems (unearthed systems) – for a reliable power supply

The IT system in medical locations

The use of an IT system is the backbone of a reliable power supply in medical locations. Contrary to an earthed system (TN system) there is no conductive connection between active conductors and the protective earthing conductor within the IT system.

Thus four essential demands are met:

- When a first insulation fault occurs the power supply is not interrupted by the tripping of a protective device.
- Medical electrical equipment continues to function.
- Fault currents are reduced to an uncritical level for patient and medical staff.
- No panic breaks out in the operating theatre because power failure is averted.
- Many national and international standards regard the use of the IT system as the backbone of a safe power supply in medical locations, for example:

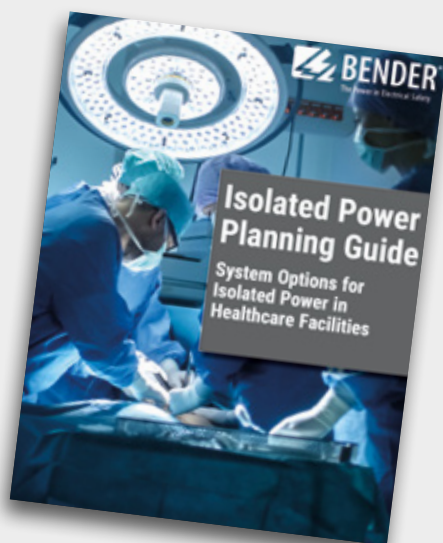

Special brochure for: **NEC/NFPA/UL/CSA/JES/AS**
<https://www.benderinc.com/solutions/healthcare/>

International:	IEC 60364-7-710
Germany:	DIN VDE 0100-710
Austria:	ÖVE-EN7/ÖNORM E 8007/A1
France:	NFC 15-211
Italy:	CEI 64-8
Brazil:	NBR 13.534
UK:	BS 7671 GN7/HTM06-01
Norway:	NEK 400-7-710
Spain:	UNEEN 20460-7-710
Belgium:	T 013
Finland:	SFS 6000/HD60364-7-710
Hungary:	MSZ 2040 HD 60364-7-710
Ireland:	ETCI 10.1
Netherlands :	NEN 1010
Slovakia:	STN 33 2000-7-710 (332000)
South-Africa:	SANS10142-1
China:	GB16895//GB50333
Indonesia:	SNI 0225:2011/BAB 8.27
Malaysia:	MS IEC 60364-7-710 / MS 2366
South Korea:	KS C IEC 60364-7-710 / Electrotechnical Regulation Article 249
Thailand:	TISI 2433-2555/IEC 2433-2555
Vietnam:	TCVN 7447-7-710

A

Insulation monitoring – safety plus thanks to advance information

The medical IT system consists of an isolating transformer, a monitoring device to monitor the insulation resistance, transformer load and temperature and a remote alarm indicator and test combination, installed in the operating theatre or at a manned nurse station nearby. Continuous insulation monitoring (IEC 60364-7-710, section 710.411.6.1.101) ensures that a deterioration in insulation resistance is immediately detected and signalled but (this is the decisive factor) there is no power supply interruption and continuity of operation is guaranteed.

The IT system transformer

In accordance with IEC 60364-7-710, section 710.512.1.101, the rated output of the transformer shall not be less than 0.5 kVA and shall not exceed 10 kVA. Single-phase transformers shall be used. The secondary voltage shall not exceed AC 250 V, even if three-phase systems are fitted. Three-phase systems are allowed for three-phase loads only.

The insulation monitoring device

The insulation monitoring device isoMED427P is a vital unit to ensure the availability of the IT system. Connected between system and earth, it continuously monitors the insulation resistance. The integrated AMP measuring principle allows insulation faults even with DC components to be precisely recorded and indicated. Simultaneously, the ISOMETER® isoMED427P monitors the load current and the temperature of the transformer. Additionally it meets the requirements of IEC 60364-7-710, section 413.1.5 and IEC 61557-8, AnnexA.

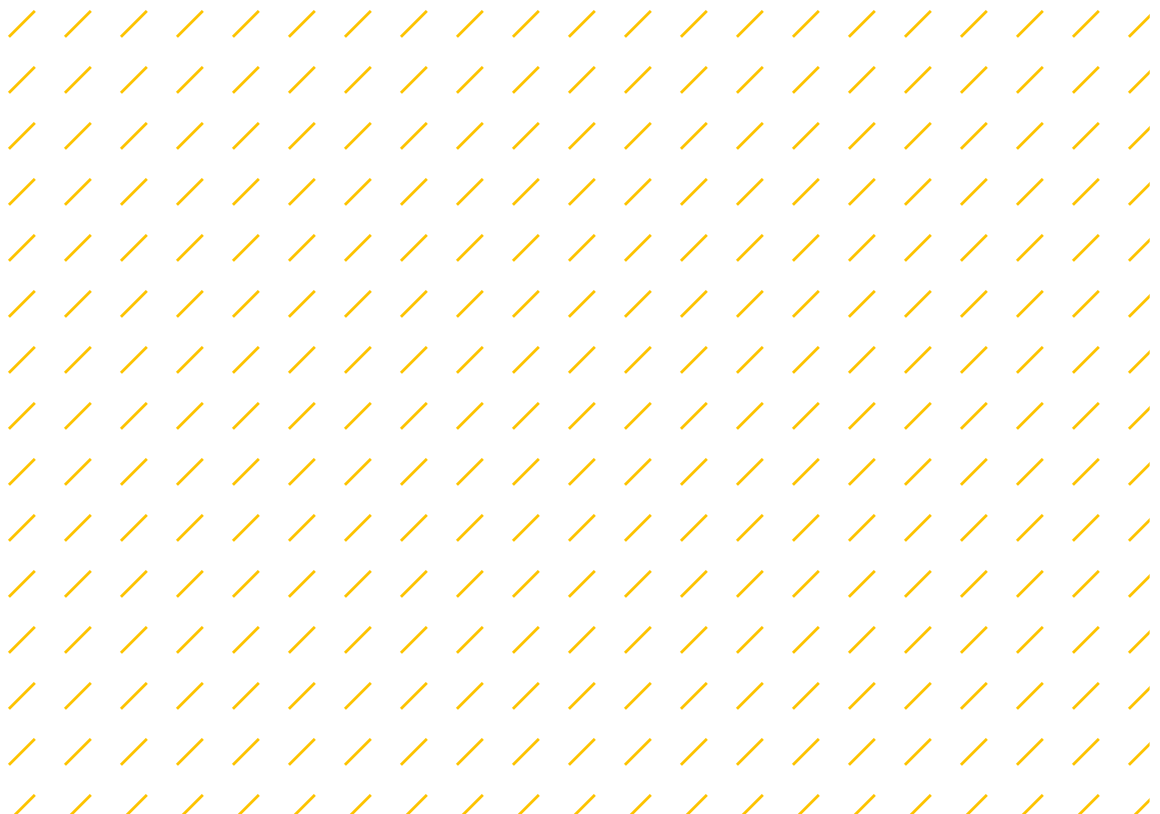

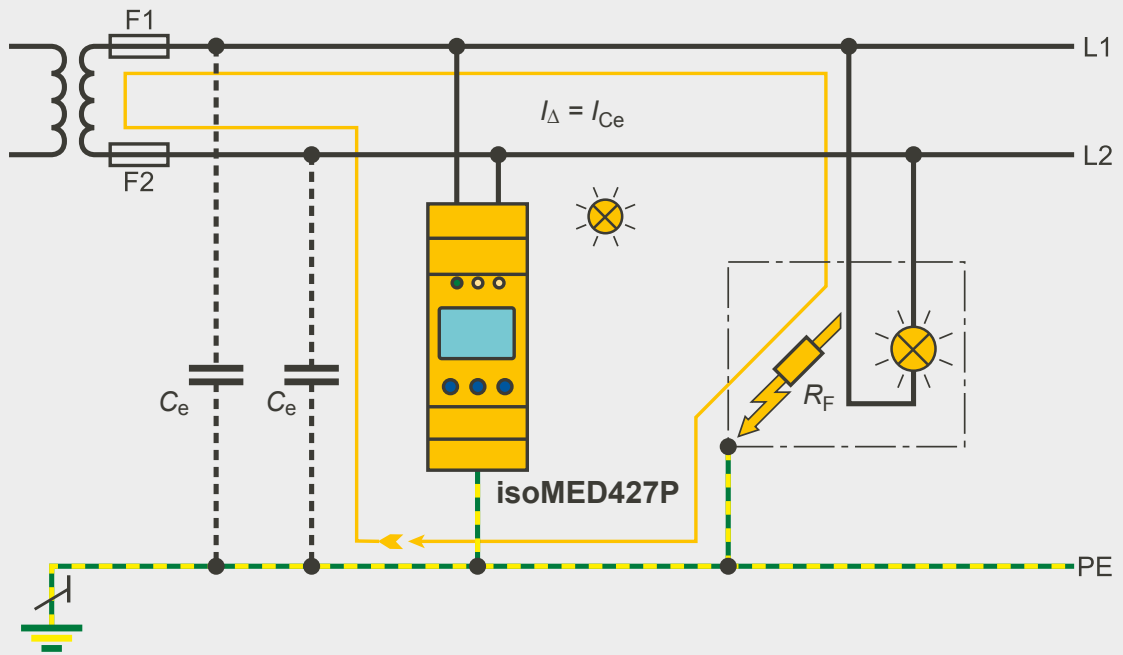

IT system with insulation monitoring by ISOMETER® isoMED427P

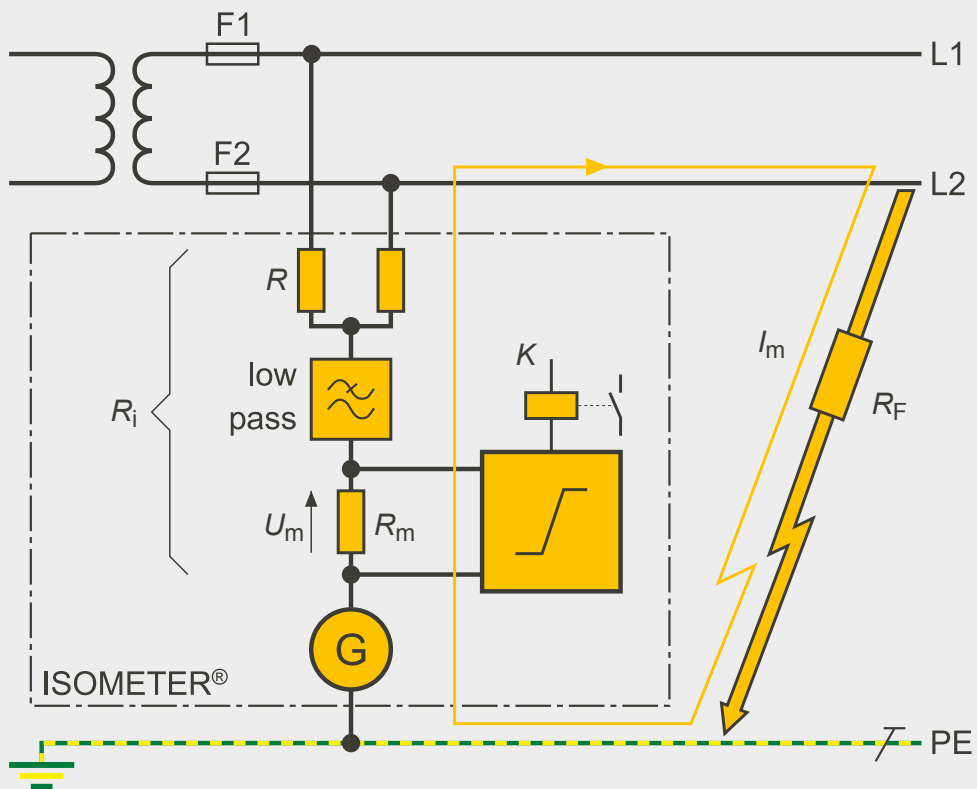

Function principle of insulation monitoring

B

How do you avoid dangerous overloads?

Load and temperature monitoring

The load an IT system transformer can put at the user's disposal is not endless. Therefore monitoring of overload and transformer temperature according to IEC 60364-7-710, section 411.6.3.101 is required.

- Measurement and indication of excessive heating of the transformer sensed by PTC resistors. [$>^{\circ}\text{C}$]
- Measuring and recording of the load current sensed via measuring current transformers. [$>\text{A}$]
- Thus, an overload of the system can effectively be signalled and the staff is informed by an optical and acoustical signal, so that the load can be reduced by switching off unnecessary equipment.

In the main feeder of the IT system transformer, overcurrent protective devices are only used for protection against short-circuits, so that an overload does not lead to a power failure. Consequently the running of the medical technical equipment is not at any risk.

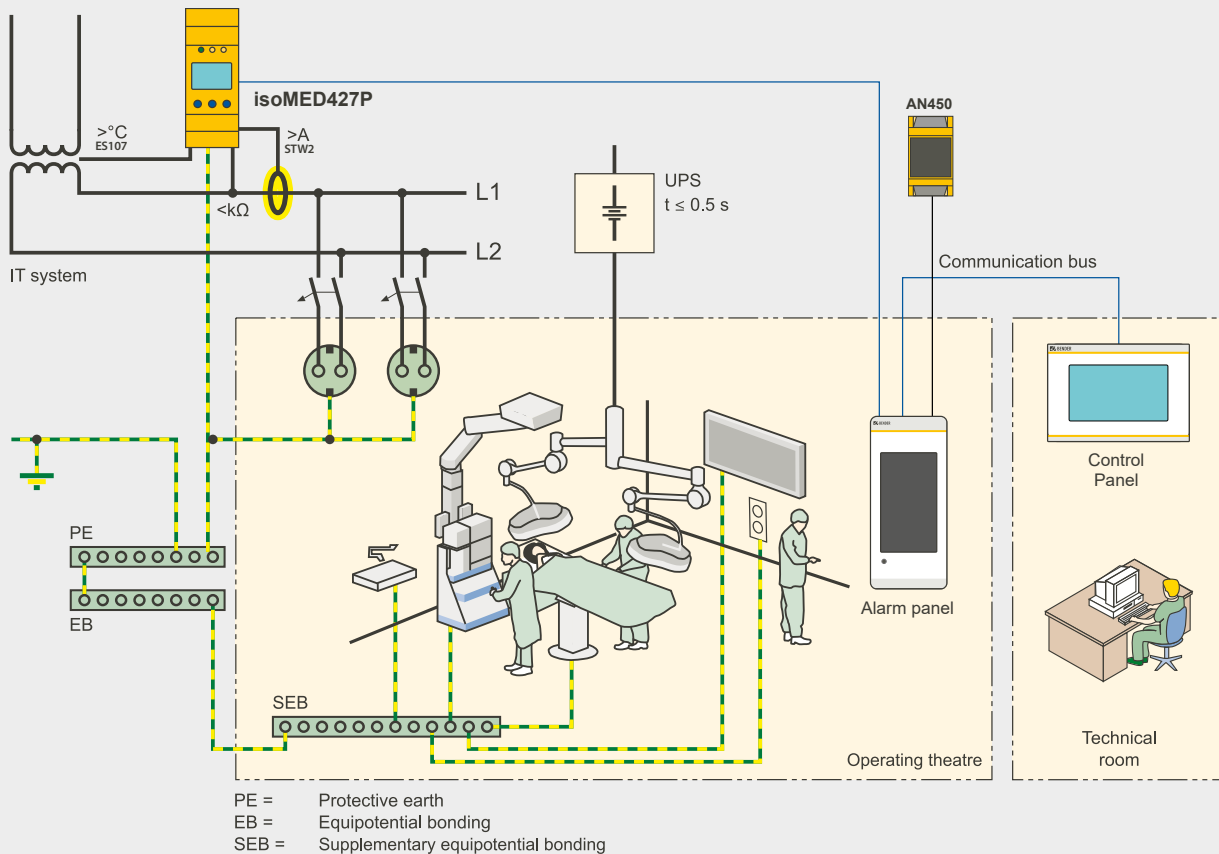

PE = Protective earth
EB = Equipotential bonding
SEB = Supplementary equipotential bonding

IT system with load and temperature monitoring

C

How do you inform your staff?

Continuous information about the status of the electrical installation is vital where reliability of supply is of paramount importance.

Remote alarm indicator and test combination CP305

The remote alarm indicator and test combinations of the CP305 meet the requirements of IEC 60364-7-710, section 710.411.6.3.101, for modern information and communication systems in hospitals in various ways. Installed in medical locations, the CP305 provides audible and visual signals, to immediately inform the staff. The CP305 contains a full graphic to indicate the insulation resistance and the load current as well as an alarm LED and functions for "Isometer testing" and "buzzer off".

The CP305 only shows the important information required in a given situation, in this way confusion caused by a flood of information is prevented. As users have the choice of more than 25 national languages, the CP305 is perfectly designed for international use. The CP305 version allows programming of individual alarm text messages, for twelve additional digital inputs from other electrical equipment (e. g. monitoring of medical gases) via the bus.

Cost-saving installation

The exchange of information between the ISOMETER® isoMED427P and the CP305 takes place via a time and cost-saving installation of a two-wire bus. This facilitates the installation of simple parallel indications and information networks.

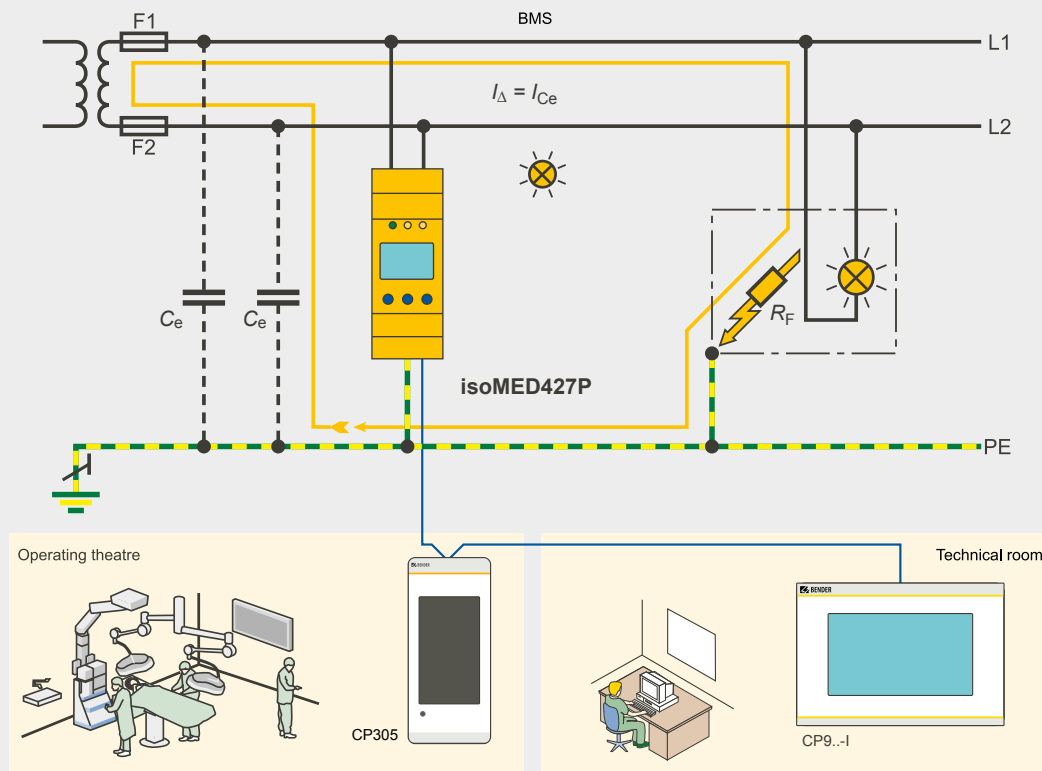

Staff information with MK2430

D

How do you avoid dangers in case of public electricity supply failure?

Due to the vital importance of electrical safety in hospitals, healthcare facilities mostly have at least two independent sources of power supply at their disposal (e. g. public electricity supply, generators, UPS). In this way, power failures of the public electricity supply do not lead to a failure of medical electrical equipment that exposes patients to danger.

According to IEC 60364-7-710 in medical locations, the distribution system should be designed and installed to facilitate the automatic changeover from the main distribution system to the electrical safety power source feeding essential loads. This automatic changeover device requires a „safe separation“ between systems as defined in IEC 60364-5-536.2.2.3,

which does not allow semiconductor devices to be used as isolating devices.

IEC 60364-7-710, 710.560.6.101 In case of a failure of the general power supply source, the electric source for safety services shall be energized to feed the equipment stated in 710.560.6.103.1, 710.560.6.103.2 and 710.560.6.103.3 with electric energy for a defined period of time and within a pre-determined transfer time.

Depending on their medical tasks, Group 1 and Group 2 medical locations have different needs concerning the permitted changeover period and the tolerable duration of a power interruption.

Power supply sources with ... a changeover period < 0.5 s

- Luminaires of operating theatre tables and other essential luminaires for a minimum period of 3 hours.

... a changeover period < 15 s

- Safety lighting
- Medical electrical equipment in Group 2 medical locations
- Equipment of medical gas supply
- Fire detection

... a changeover period > 15 s

- Equipment essential for maintaining hospital services (e. g. cooling equipment, cooking equipment, sterilisation equipment)

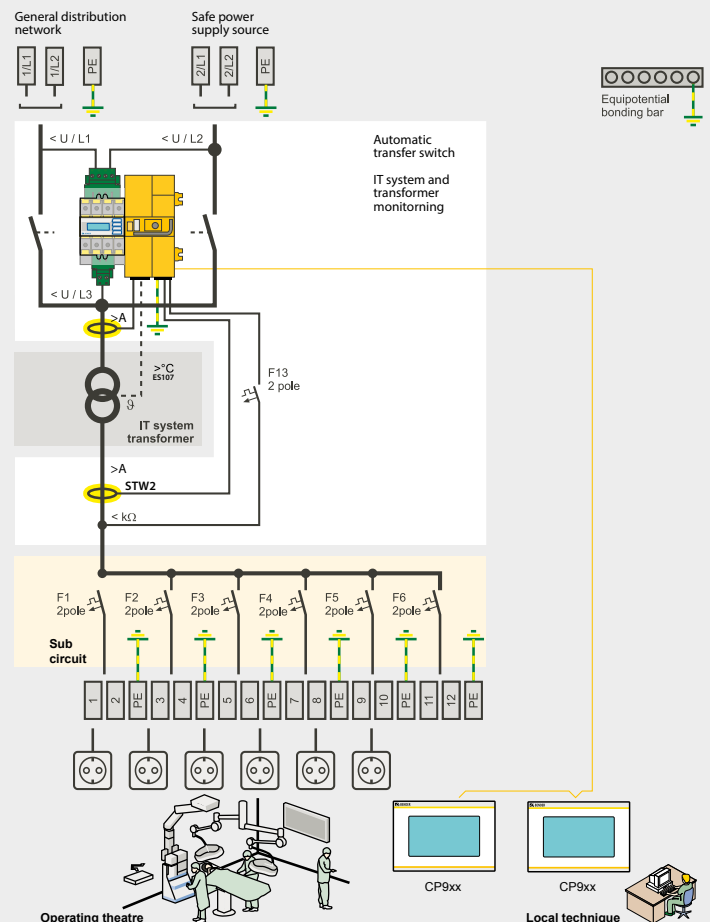

Power supply for Group 2 medical locations

Three supply options for IT systems:

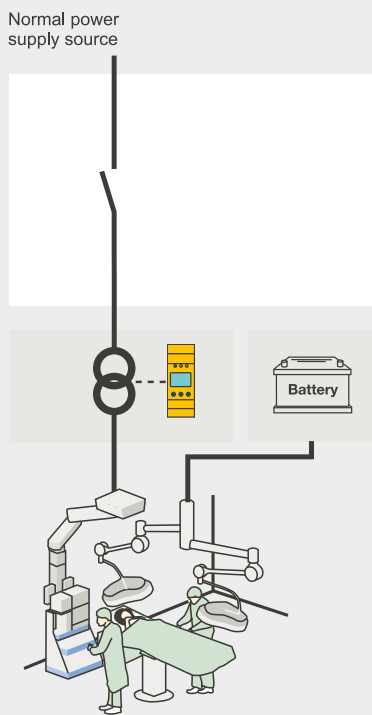

IT system with one supply cables

1. One supply cable

The IT system is supplied by only one supply cable. If the supply cable is interrupted, a complete power failure is tolerated. (This system is not permitted in Germany and Austria).

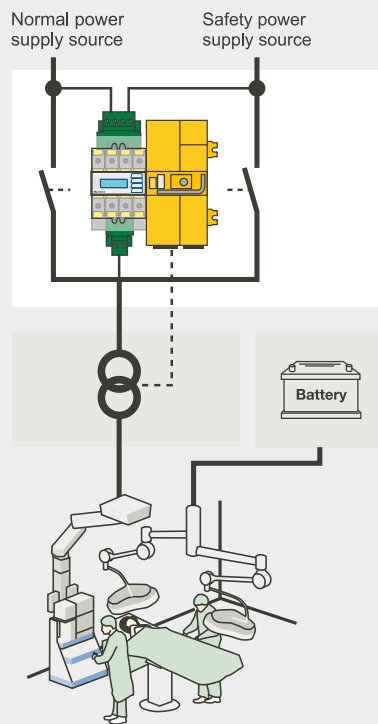

IT system with two supply cables

2. Two supply cables

The IT system is supplied by two supply cables. In the event the first cable fails, automatic transfer to the second cable, takes place.

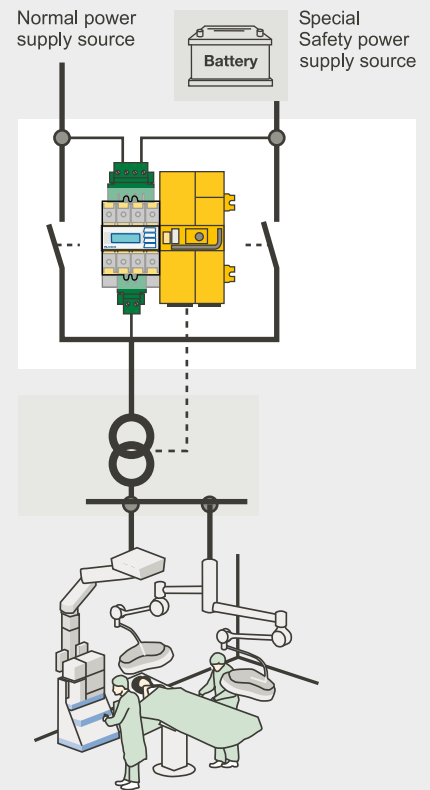

IT system with two supply cables and a special safety power supply source

3. Two supply cables but with a safety power source

The second cable derives the power from a special safety power supply source. That ensures the supply of life-support equipment, independently from the external and internal power supply.

In case, the ATICS® transfer switching device is installed, the following tasks are carried out:

- Voltage monitoring of the preferred and second supply.
- Transfer to the second supply if the voltage at one or several line conductors drops by more than 15 % of the nominal voltage.
- Monitoring of the switching elements.
- Safe separation between supply lines
- Automatic return to the preferred supply on recovery of its voltage.
- Insulation, load and temperature monitoring of the IT system.
- Additionally, the technical staff has optical and acoustical status information of the medical IT system by CP305... remote alarm indicators.

E

What else can you do for increased safety? Insulation fault location for critical rooms

Insulation fault location in IT systems with the EDS151 system

In medical locations, IT systems with insulation monitoring are intended to supply medical electrical equipment. That ensures reliable power supply, even when a first fault occurs. In addition a fast location and elimination of the insulation fault is required. Particularly in the view of the variety of electrical

equipment (e. g. socket outlet circuits) used in intensive care units, insulation fault location is disruptive and costly in terms of time and money. The EDS151 insulation fault location system is the modular solution for this problem. It facilitates precise localisation of insulation faults without disruption to the operation of the power system.

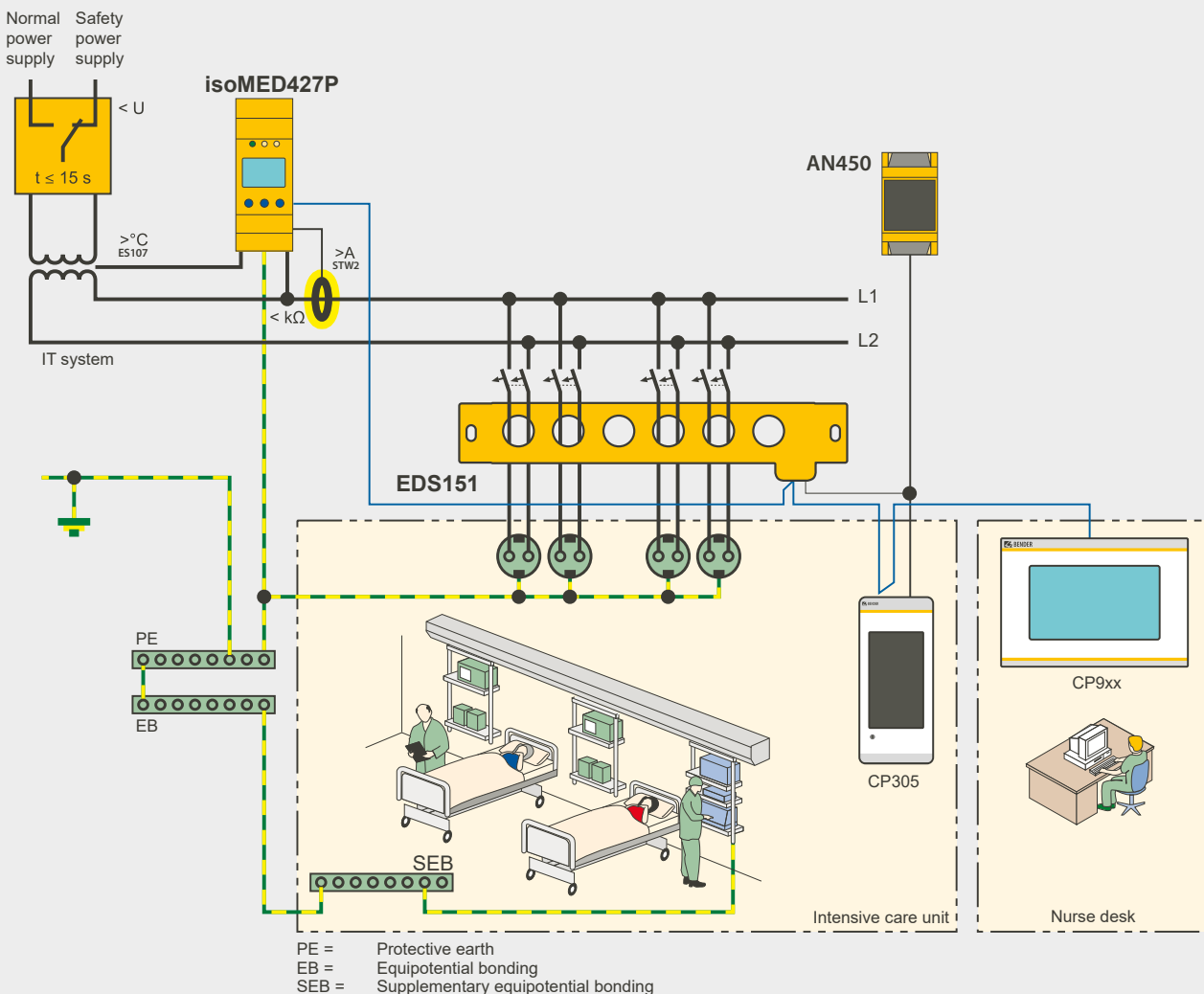

EDS151 insulation fault location system applied in an intensive care unit

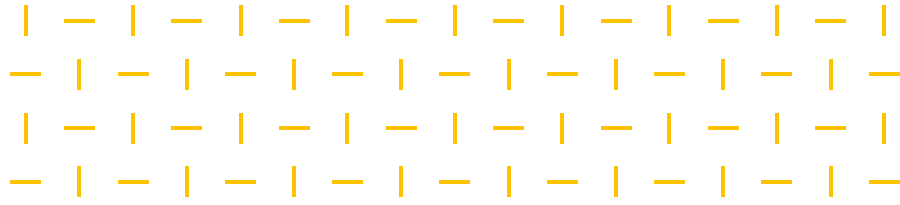

Advantages:

- Insulation fault location during operation
- Fast localisation of faulty circuits/equipment
- Reduced maintenance costs
- Central indication via text message remote alarm indicator and operator panels.

System functions:

- Indication of faulty branch circuits.
- Easily retrofitting with existing installations due to the modular design.
- Measuring current transformers in different sizes and designs.
- Up to 528 sub circuits can be monitored.
- Communication via two-wire connection.
- Universally applicable for all IT systems.

Function principle:

The EDS151 system works in combination with a central insulation monitoring device with integrated pulse generator, e. g. an ISOMETER® isoMED427P. After an insulation fault the isoMED427P starts automatically the fault location by generating a test signal. Its amplitude and duration are limited. The signal flows via the location of the insulation fault and through all measuring current transformers within the insulation fault path. The EDS151 system scans all measuring current transformers.

The EDS151 with its LEDs or the central control and indicating device (e.g. CP305) provide fault location information.

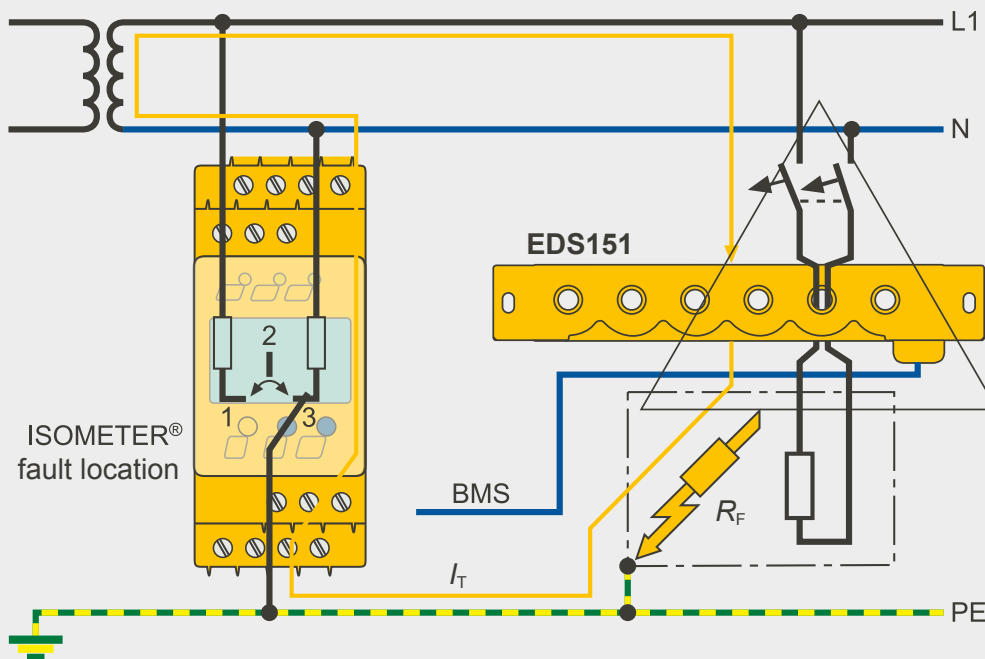

Function principle of the EDS151 system

E

What else can you do for increased safety? Residual current monitoring for TN-S systems

TN-S systems: advance information with RCM and RCMS

In order to avoid leakage currents, the IEC 60364-7-710 recommends the installation of the TN-S system (five conductors) downstream of the main distribution board of the building. This standard also recommends to monitor the system in order to ensure a high insulation level of all conductors in group 0 and 1 rooms. For fulfilling the task of monitoring, the use of RCM (residual current monitors) respectively RCMS (residual current monitoring systems), which detect and indicate fault currents at an early stage instead of unintentional switching off, has proved to be successful.

According to IEC 60364-7-710, the use of the TN-S system (earthed system) in medical locations of **Group 2** is restricted to the supply of:

- Circuits for the supply of operating tables.
- Circuits for X-ray units.
- Circuits for large equipment with a rated power greater than 5 kVA.
- Circuits for non-critical electrical equipment (non life support).

Advantages:

- Prewarning before unexpected interruptions occur, prevention of fire risks and damage to property.
- Convenient monitoring of the electrical installation from a central control room.
- Adjustment to the system ambient conditions by individual adjustable response values.

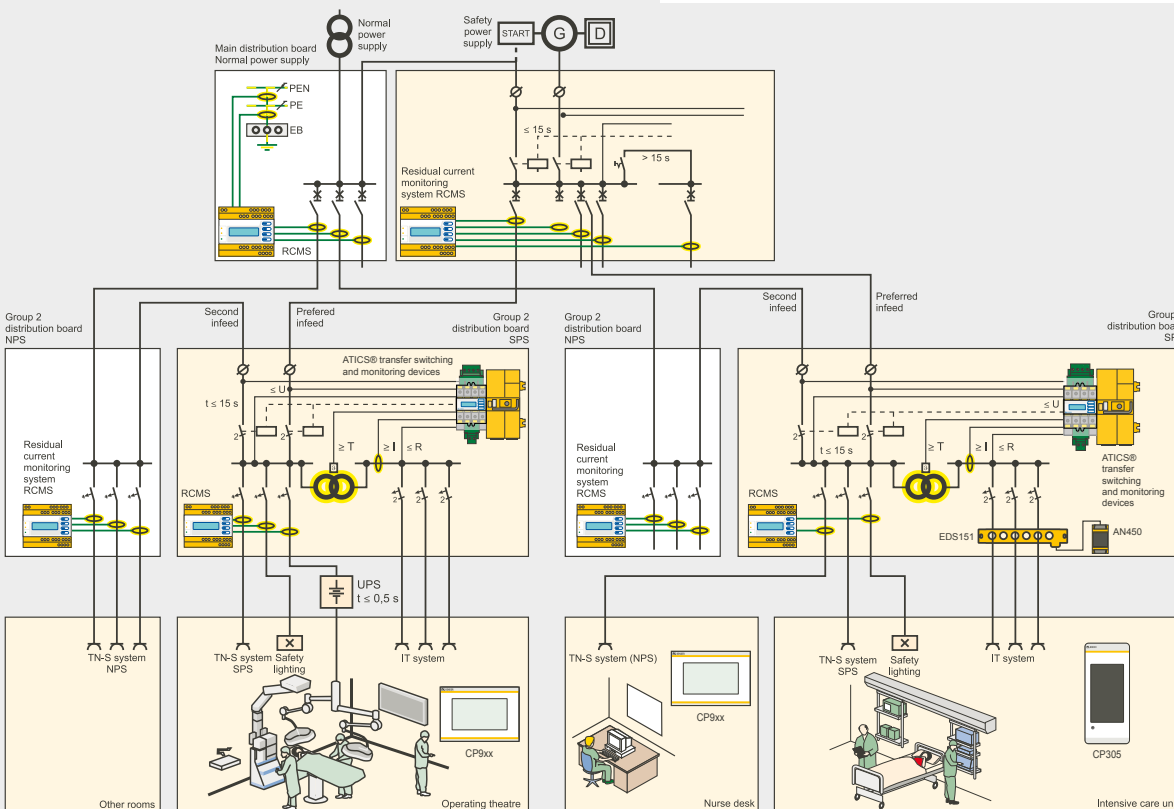

RCMS system in a hospital NPS = Normal power supply SPS = Safety power supply











The complete solutions

Insulation monitoring Devices (IMD)

Indication and control panel

								
		IR427	iso-MED427P	IR426-D47	MK7	CP305	MK2430	CP9xx
Page		20	22	24	20	26	28	32
System	1ph	✓	✓	—	—	—	—	—
	3ph	—	CMS460-D4-2	—	—	—	—	—
Monitoring	Insulation	✓	✓	—	✓	✓	✓	✓
	Overload	✓	✓	—	✓	✓	✓	✓
	Temperature	✓	PTC PT100 PT	—	✓	✓	✓	✓
	Fault location	—	✓	—	—	✓	✓	✓
	Changeover	—	—	—	—	✓	✓	✓
Indication	LED	✓	✓	✓	✓	✓	✓	—
	Text display	—	—	—	—	Graphic	Dot matrix	Graphic
	7-Segment	✓	✓	✓	—	—	—	—
	Data logging	—	—	—	—	✓	✓	✓
	Individual text	—	—	—	—	✓	✓	✓
Communication	BMS	—	✓	—	—	✓	✓	✓
	4-wire	✓	—	—	✓	—	—	—
	TCP/IP	—	—	—	—	—	—	✓
	Modbus RTU	—	—	—	—	—	—	✓
	Modbus TCP	—	—	—	—	—	—	✓
Power supply units								
Transformer for operating theatre lamps	AN450	—	—	—	—	✓	✓	—
	ESL0107	—	—	✓	—	—	—	—
	ES710	✓	✓	—	—	—	—	—
	DS0107	—	✓	—	—	—	—	—

Three phase loads	Change-over	Insulation fault location system		Isolating transformer		Power Quality and Energy Measurement		Communication solutions
								
CMS460-D4-2	ATICS®	EDS151	EDS441-L	ES710	DS0107	PEM...	CP9..-I	COM465XX
30	34	38	40	44	46	48	48	50
—	✓	—	—	✓	—	✓	✓	✓
✓	✓	—	—	—	✓	✓	✓	✓
—	✓	—	—	—	—	—	✓	✓
✓	✓	—	—	—	—	—	✓	✓
—	✓	—	—	—	—	—	✓	✓
—	✓	✓	✓	—	—	—	✓	✓
—	✓	—	—	—	—	—	✓	✓
✓	✓	—	—	—	—	✓	—	✓
Graphic	✓	—	—	—	—	✓	✓	—
—	—	—	—	—	—	✓	—	—
—	✓	—	—	—	—	✓	✓	✓
—	—	—	—	—	—	—	✓	✓
✓	✓	✓	—	—	—	—	✓	✓
—	—	—	—	—	—	—	—	—
—	—	—	—	—	—	—	✓	✓ ¹⁾
—	—	—	—	—	—	✓	✓	✓ ³⁾
—	—	—	—	—	—	✓	✓	✓ ²⁾
—	—	✓	—	—	—	—	—	—
—	—	—	—	—	—	—	—	—
—	—	—	—	—	—	—	—	—
✓	—	—	—	—	—	—	—	—

1) only COM465XX

2) only COM461MT

3) only COM462RTU

ISOMETER® IR427 + MK7

Insulation-, load- and temperature monitoring device

The ISOMETER® of the IR427 series is designed to monitor the insulation resistance of AC circuits (medical IT systems). At the same time, the load current and temperature of the IT system transformer can be monitored.



Features:

ISOMETER® IR427

- Insulation monitoring for medical IT systems
- Load and temperature monitoring for IT system transformers
- Adjustable response value for insulation monitoring
- Adjustable load current response value
- Integrated voltage supply for four alarm and test combinations MK7
- Temperature monitoring with PTC thermistor or bimetal switch
- Connection monitoring earth
- LEDs: Power On, Alarm 1, Alarm 2
- Internal/external test button
- Configurable alarm relay: N/O or N/C operation selectable
- Self monitoring with automatic alarm
- Compact two-module enclosure (36 mm)
- Four-wire interface for four alarm indicator and test combinations MK7
- AMP measuring principle for monitoring AC with galvanically connected DC systems (e.g. in power supplies)

Remote alarm indicator and test combination MK7

- Easy-to-clean front foil surface
- Label field
- Panel frame alpine white
- Alarm LEDs: Power On, insulation fault overload, overtemperature
- Test button, mute button
- Standard flush-mounting enclosure 66 mm

Standards:

The ISOMETER® of the IR427 series complies with the requirements of the device standards:

IEC 60364-7-710, IEC 61557-8, AnnexA and DIN VDE 0100-710.

Technical data

Rated impulse voltage	4 kV
Supply voltage U_s	AC 70...264 V, 42...460 Hz

Insulation monitoring

Response value R_{an}	50...500 k Ω
Relative uncertainty	$\pm 10\%$
Hysteresis	25 %
Response time t_{an} at $R_f = 0.5 \times R_{an}$ and $C_e = 0.5 \mu F$	≤ 5 s
Permissible system leakage capacitance C_e	$\leq 5 \mu F$

Load current monitoring

Response value, adjustable	5...50 A
----------------------------	----------

Temperature monitoring

Response value (fixed value)	4 k Ω
Release value (fixed value)	1.6 k Ω
PTC resistors acc. to DIN 44081	max. 6 in series

Interface for MK7

Cable length, twisted in pairs, shielded	200 m
Cable (twisted in pairs, one end of shield connected to PE) recommended:	J-Y(St)Y min. 2x0.8

Power supply (terminals 1 and 2):

U_{off}	DC 24 V
I_{max} (max. 4 MK7)	80 mA

Communication (terminal 3 and 4):

Interface/protocol	RS-485/proprietary, no BMS
Terminating resistor	120 (0.25 W), internal, switchable

Test of the Electromagnetic Compatibility (EMC)

EMC	IEC 61326-2-4
Operating temperature	-25...+55 °C

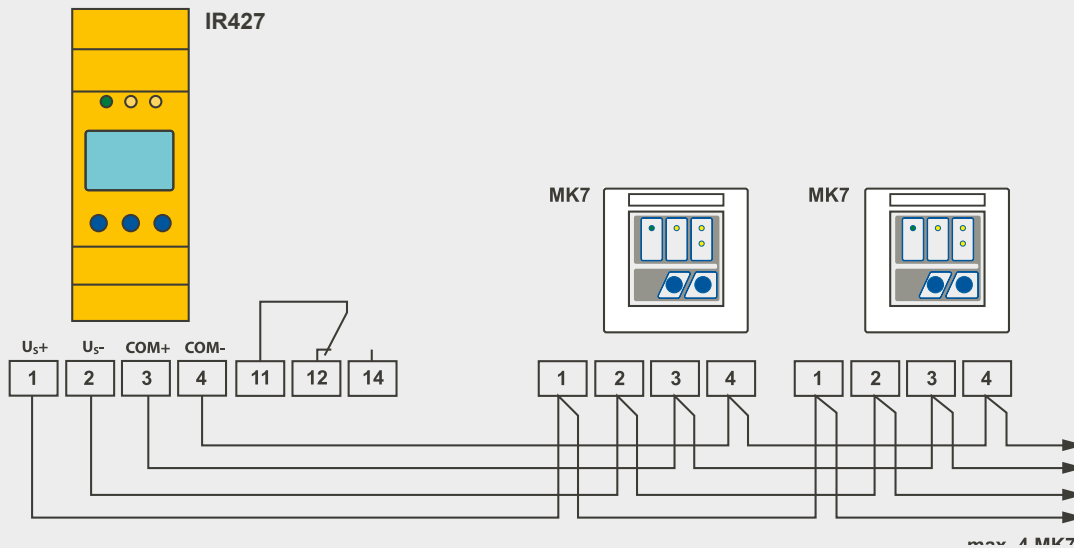
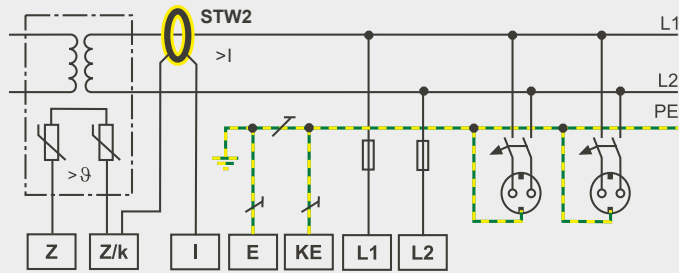

Wiring diagram IR427 + MK7

Ordering information

Supply voltage U_s		Type	Art. No.
AC	DC		
70...264 V 42...460 Hz	-	IR427-2	B72075300
-	18...28 V	MK7	B95100201

¹⁾ Absolute values

Accessories

Type designation	Art. No.
Mounting clip for screw mounting (1 piece per device)	B98060008
MK-cavity-wall-box-60mm	B95100203
Mounting frame XM420	B990994

Suitable system components

Type designation	Type	Art. No.
Measuring current transformers	STW2	B942709
Temperature sensor (PTC)	ES0107	B924186

ISOMETER® isoMED427P

Insulation-, load- and temperature monitoring device (insulation fault location integrated)

The ISOMETER® isoMED427P monitors the insulation resistance of unearthed AC circuits which may also contain DC components (medical "IT systems"). At the same time, the load current and temperature of the IT system transformer is monitored. In combination with EDS series insulation fault locators and the appropriate measuring current transformers, the isoMED427P is designed to set up the respective equipment for insulation fault location.

Features:

- Insulation monitoring for medical IT systems
- Adjustable response value for insulation monitoring
- Locating current injector for insulation fault location systems
- Load and temperature monitoring for IT system transformers
- Adjustable load current response value
- Temperature monitoring with PTC thermistor or bimetal switch
- Self monitoring with automatic alarm
- PE connection monitoring
- Internal/external test button
- LEDs: Power On, Alarm 1, Alarm 2
- Configurable alarm relay: N/O or N/C operation selectable
- Compact two-module enclosure (36 mm)
- BMS interface
- AMP measuring principle for monitoring AC with galvanically connected DC systems (e.g. in power supplies)

Standards:

The ISOMETER® of the isoMED427P series complies with the requirements of the device standards: IEC 60364-7-710, IEC 61557-8, AnnexA, IEC 61557-9 and DIN VDE 0100-710.



ISOMETER® isoMED427P

Technical data

Rated impulse voltage	4 kV
Supply voltage U_s	AC 70...264 V, 47...63 Hz

Insulation monitoring acc. to IEC 61557-8

Response value R_{an}	50...500 k Ω (50 k Ω)*
Relative uncertainty	± 10 %
Hysteresis	25 %
Response time t_{an} at $R_f = 0.5 \times R_{an}$ and $C_e = 0.5 \mu F$	≤ 5 s
Permissible system leakage capacitance C_e	5 μF
Fault location acc. to	IEC 61557-9
Test current	≤ 1 mA

Measuring circuit

Measuring voltage U_m	± 12 V
Measuring current I_m (at $R_f = 0 \Omega$)	$\leq 50 \mu A$
Internal DC resistance R_i	≥ 240 k Ω
Impedance Z_i at 50 Hz	≥ 200 k Ω
Permissible extraneous DC voltage U_{fg}	\leq DC 300 V

Load current monitoring

Response value, adjustable	5...50 A (7 A)*
Relative uncertainty	± 5 %
Hysteresis	4 %
Nominal frequency f_n	47...63 Hz
Setting values load current measurement:	
Transformer	3150 VA 4000 VA 5000 VA 6300 VA 8000 VA 10000 VA
alarm 1~	14 A 18 A 22 A 28 A 35 A 45 A

Interface

Interface/protocol	RS-485/BMS
Baud rate	9.6 kbit/s
Cable length	≤ 1200 m
Cable (twisted in pairs, one end of shield connected to PE) recommended:	J-Y(St)Y min. 2x0.8
Terminating resistor	120 (0.25 W), internal, switchable
Device address, BMS bus	2...90

Test of the Electromagnetic Compatibility (EMC)

EMC	IEC 61326-2-4
Operating temperature	-25...+55 °C

() * factory setting

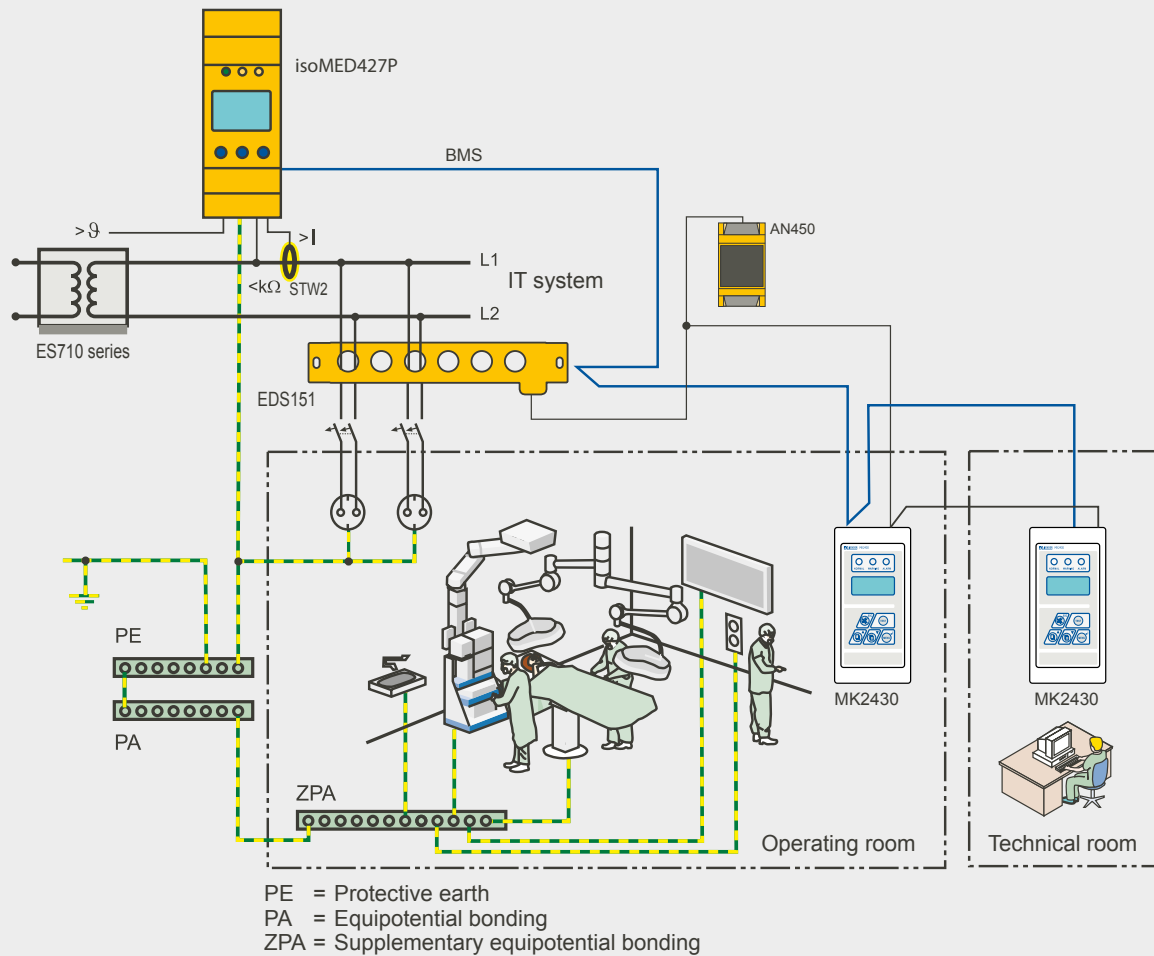

Function principle of isoMED427P

Ordering information

Supply voltage $U_s = U_n^{1)}$	Type	Art. No.
AC		
70...264 V, 47...63 Hz	isoMED427P-2	B72075301
	isoMED427P-PT	B72075307

Accessories

Type designation	Art. No.
Mounting clip for screw mounting (1 piece per device)	B98060008
Mounting frame XM420	B990994

Suitable system components

Type designation	Type	Page
Measuring current transformers	STW2	B942709
Temperature sensor (PTC)	ES0107	B924186

ISOMETER® IR426-D47

Insulation monitoring device for operating theatre lamps

The ISOMETER® IR426-D47 monitors the insulation resistance of IT systems (isolated power) for operating theatre lamps.

Features:

- For DC/AC IT systems 0...132 V
- Response value 10...200 kΩ
- Built-in test button
- Built-in Power On and alarm LED
- Two alarm relays with changeover contacts

Standards:

The ISOMETER® IR426-D47 complies with IEC 61557-8 + DIN EN 61557-8 (VDE 0413-8), ASTM F 1669M-96. When installing the device, the safety instructions supplied with the equipment must be observed!



ISOMETER® IR426-D47

Technical data

Insulation coordination acc. to IEC 60664-1/IEC 60664-3

Rated insulation voltage	AC 250 V
Rated impulse withstand voltage/contamination level	4 kV/3

Voltage range

Operating range of U_n	AC 0...132 V/DC 0...132 V, 42...62 Hz
--------------------------	---------------------------------------

Supply voltage

Supply voltage U_s	AC 70...300 V, 15...460 Hz/DC 70...300 V
Power consumption	≤ 4 VA

Response value

Response value R_{an1} (Alarm 1)	10...200 kΩ (50 kΩ)*
Response value R_{an2} (Alarm 2)	10...200 kΩ (50 kΩ)*
Relative uncertainty	± 15 %
Hysteresis	25 %

Measuring circuit

Measuring voltage U_m	± 12 V
Measuring current I_m (at $R_f = 0 \Omega$)	≤ 100 μA
Internal DC resistance R_i	≥ 120 kΩ
Impedance Z_i at 50 Hz	≥ 117 kΩ
Permissible extraneous DC voltage U_{ig}	≤ DC 132 V
Permissible system leakage capacitance C_e	≤ 20 μF

Test of the Electromagnetic Compatibility (EMC)

EMC	IEC61326-2-4
Operating temperature	-25...+55 °C

() * factory setting

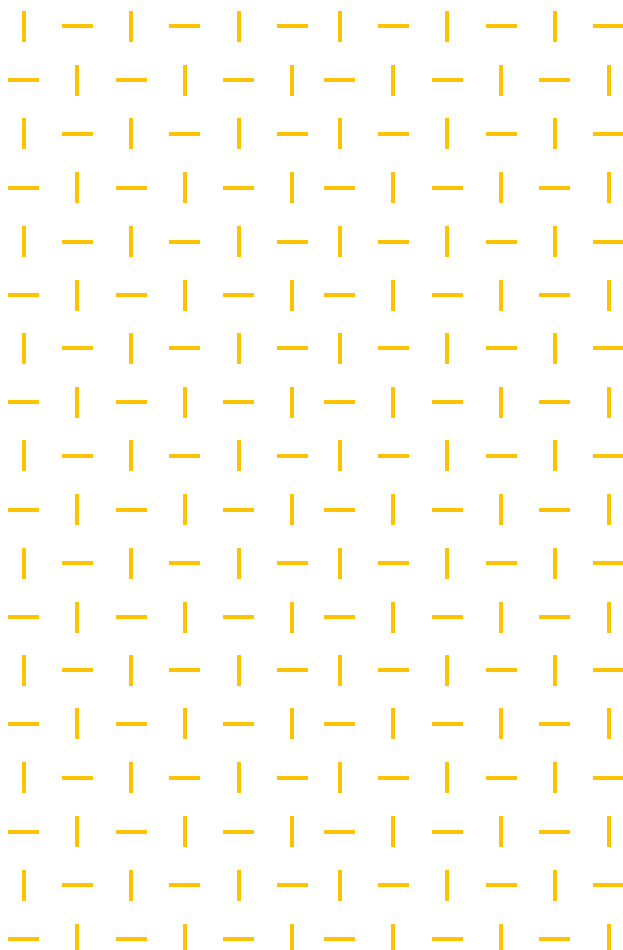

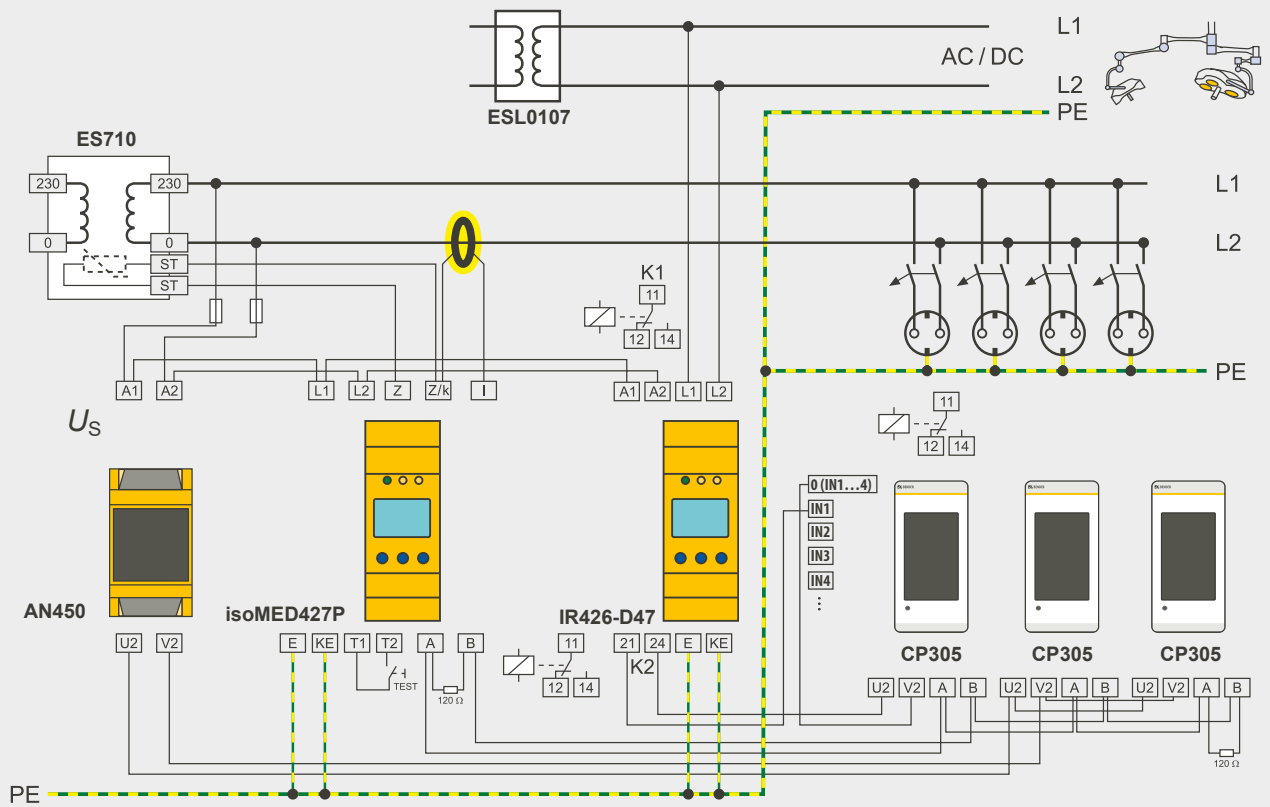

Example of a monitoring system for IT systems and operating theatre luminaires circuits in medical locations according to IEC 60364-7-710 and DIN VDE 0100-710

Ordering information

Supply voltage ¹⁾ U _s	Type	Art. No.
AC DC		
70...300 V, 15...460 Hz 70...300 V	IR426-D47	B71016307

Accessories

Type designation	Art. No.
Mounting clip for screw mounting (1 piece per device)	B98060008

Suitable system components

Type designation	Type	Page
Isolating transformer for operating theatre lamps	ESL0107-0	B924204

COMTRAXX® CP305

Remote alarm indicator for medical locations and other areas

These small panels are mainly used in intensive care units, preparation rooms, and recovery rooms. Simultaneously to the information at the ward base, the medical personnel immediately receives a notification when there is a disruption of the power supply. They hence can respond to it without delay.

For the indication of more information on the display, for example messages from a battery-based safety power supply system, only much larger panels are available. The remote alarm indicators of the CP305 series can be included in the bus technology.

Device features:

- 5" touch screen
- Central visual display unit for operational status and error messages of the monitored power-supply systems of medical locations in accordance with DIN VDE 0100-710
- Display of other MEDICS® system components (e.g. RCMS monitoring, ATICS® devices, etc.)

Your benefits:

- Parameter setting via web server, display or Bender Connect app
- Freely programmable alarm messages
- Flush-mounting and surface-mounting version
- Easy replacement of MK2007/MK2430 (retrofit)

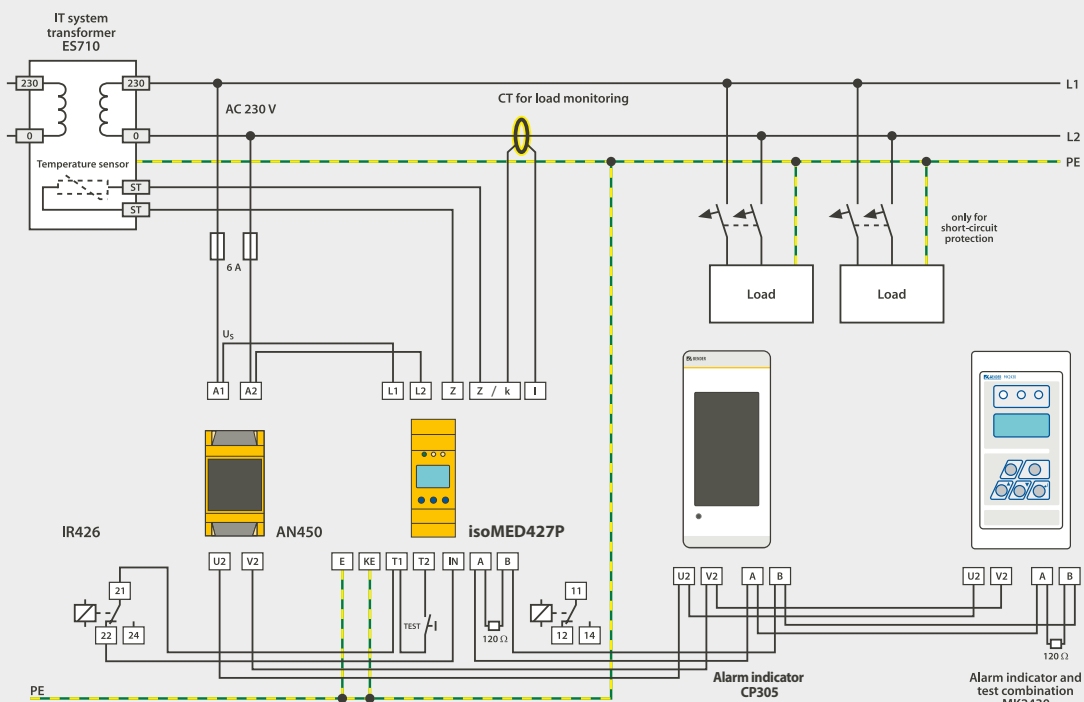

IT system with insulation, load and temperature monitoring device isoMED427P as well as remote alarm indicator CP305/MK2430

Technical data

Insulation coordination CP305 acc. to IEC 60664-1

Rated voltage	50 V
Overvoltage category	II
Pollution degree	2

Overvoltage category II and pollution degree 2 is related to the relay contacts.
Further insulation coordination takes place after functional separation.

Supply via plug-in terminal (A1 +/A2 -)

Nominal voltage	AC/DC 24 V
Operating range of the supply voltage	AC 18...28 V / DC 18...30 V
Nominal frequency	50/60 Hz
Typical power consumption	< 4.2 W
Maximum cable length when supplied via B95061210 (24 V DC power supply unit 1.75 A)	
	0.28 mm ² 75 m
	0.5 mm ² 130 m
	0.75 mm ² 200 m
	1.5 mm ² 400 m
	2.5 mm ² 650 m

Stored energy time in the event of voltage failure

Time, date	min. 2 days
Restart after power failure	min. 2 seconds

Displays

Display	5" TFT touch display (720 x 1280 px)
---------	--------------------------------------

Interfaces

Ethernet

Connection	RJ45
Data rate	10/100 Mbit/s, autodetect
DHCP	on/off (off)*
IP address (1:1 connection)	169.254.xx.yy (xx and yy individual for each device)
Net mask	nnn.nnn.nnn.nnn (255.255.0.0)*
Protocols	TCP/IP, Modbus TCP, DHCP, SNTP

Modbus TCP (CP305-IO only)

Interface/protocol	Ethernet/Modbus TCP
Operating mode	Slave

Interface/Protocol	RS485/BMS internal
Operating mode	master/slave (master)*
Baud rate	9.6 kbit/s
Cable length	< 1200 m
Shielded cable, one end of shield connected to PE recommended:	
	CAT6/CAT7 min. AWG23
	alternative: J-Y(St)Y min. 2 x 0.8
Galvanic separation	yes
Connection	"BMS A", "BMS B" (see plug-in terminal)
Terminating resistor	120 Ω (0.25 W), can be connected internally
Device address	1...90 (1)*

Digital inputs (1...12)

Number	12
Galvanic separation	yes
Operating mode	selectable for each input: active-high or active-low
Factory setting	off
Voltage range (high)	AC/DC 10...30 V
	Nominal: 24 V
Voltage range (low)	AC/DC 0...2 V
Max. current per channel (at AC/DC 30 V)	8 mA
Connection	plug-in terminals
	IN 1...4 / GND1-4
	IN 5...8 / GND 5-8
	IN 9...12 / GND 9-12
Maximum cable length	< 1000 m

Switching elements

Connection	plug-in terminal
	K1 NC; K1 NO; K1 COM
	K2 NC; K2 NO; K2 COM
Number of changeover contacts	2
Operating mode (changeover contacts)	N/C operation or N/O operation
Function	programmable
Electrical endurance under rated operating conditions, number of cycles	10,000
Minimum contact load (relay manufacturer's reference)	-

Contact data acc. to IEC 60947-5-1

Utilisation category	AC-13	AC-14	DC-12
Rated operational voltage	AC 24	VAC 24	VDC 24 V
Rated operational current	AC 2 A	AC 2 A	AC 2 A

Accessories

Description	Art. No.
Flush-mounting enclosure	B923710
Cavity-wall installation set for flush-mounting enclosures	B923711
CP305-IO plug kit	B95100151
Ethernet adapter kit (RJ45 socket insert, Cat.6 SLIM patch cable)	B95100152
CP305 surface-mounting enclosure	B95100153

Ordering details

Type	Art. No.
CP305-IO	B95100051

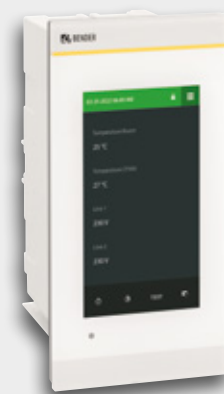

CP305

MK2430

Remote alarm indicator and test combination

The remote alarm indicator and test combination duplicates fault, alarm and operating messages of monitoring devices in accordance with IEC 60364-7-710 and DIN VDE 0100-710 (VDE 0100-710). The LC text display provides medical staff with clear and concise information. Additional information for the technical staff can be retrieved by pressing a special button. A two-wire connection between the MK2430 remote alarm indicators and the changeover and monitoring modules allows a time and cost-saving installation.

Typical applications:

- Intensive care unit with several IT systems and EDS
- Operating theatres
- Industrial applications with EDS/RCMS

Features:

- Comprehensive information: suitable for utilisation with MEDICS (isoMED427P, 107TD47) or EDS/RCMS systems
- Programmable display of customised alarms
- Signalling of medical gases messages in compliance with the relevant standards (-11 version)
- Display of test possibilities for several IT systems with evaluation and display of results
- Display of messages from UPS systems
- Individual texts for better information
- Display of messages from EDS/RCMS systems
- Standard configuration for four IT systems with EDS
- Easy-to-clean lexan front foil
- Simple parallel indication by two-wire connection
- Available for flush-mounting, surface-mounting and cable-duct mounting



MK2430

Technical data:

Supply voltage U_s	AC 18...28 V/40...60 Hz/DC 19...30 V
LC display, illuminated	4 x 20 characters

Inputs (MK2430-11 only):

Digital inputs	12
Voltage range (high)	AC/DC 15...30 V
Voltage range (low)	AC/DC 0...2 V

Interfaces:

Serial interface	RS-485 (BMS protocol)
Wire length	≤ 1200 m
USB	V 2.0/V 1.1

Test of the Electromagnetic Compatibility (EMC):

EMC immunity	to EN 61000-6-2
EMC emission	to EN 61000-6-3
Ambient temperature during operation	- 5...+ 55 °C

Relay (MK2430-11 only):

Switching elements	1 changeover contact
Operating principle, adjustable	N/C operation
Rated operational voltage	24 V AC/DC
Function	programmable (test, fault, device failure)
Programming software	TMK-Set V4.x optional

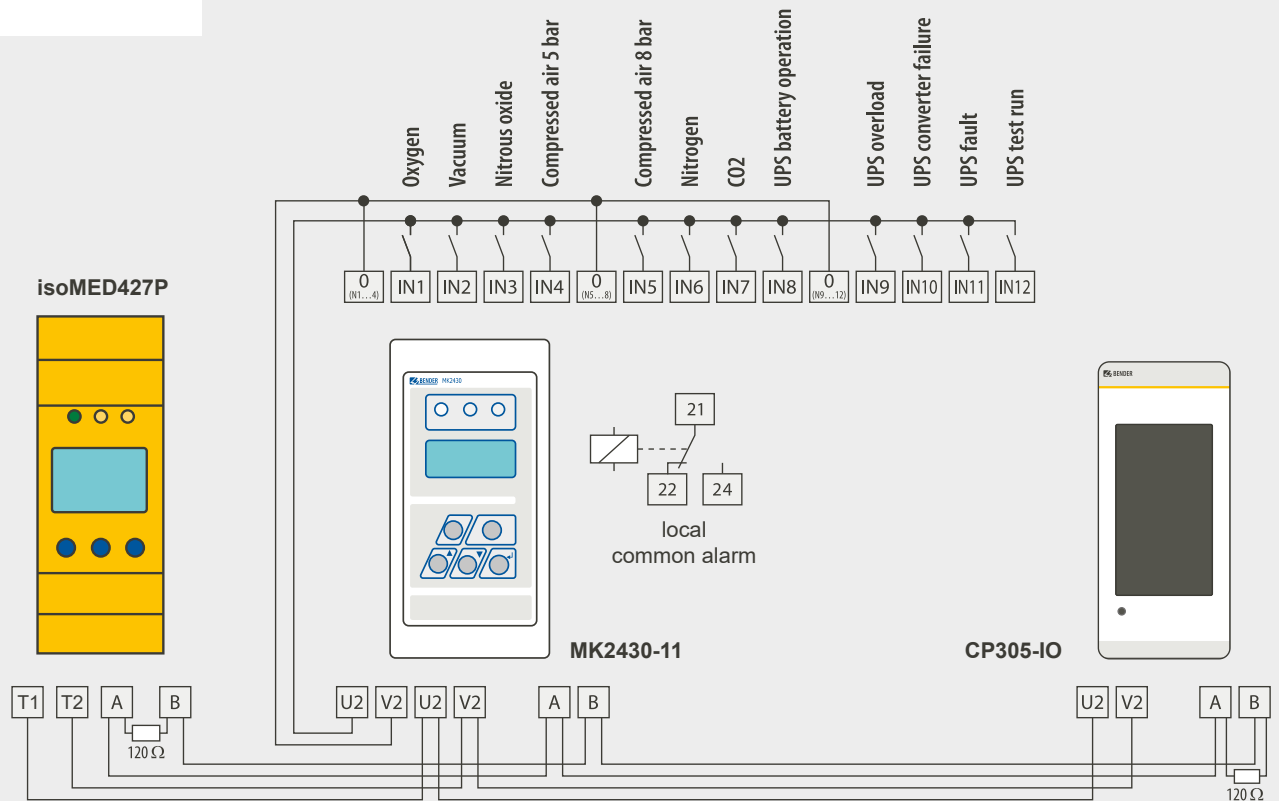

isoMED427P Insulation-, load- and temperature monitoring device, CP305 and MK2430-11 remote alarm indicator and test combination with 12 digital inputs for the communication of additional data

Ordering information

Enclosure	Digital inputs/ relay output	Type	Art. No.
Flush-mounting	12/1	MK2430-11	B 9510 0031
	-	MK2430-12	B 9510 0032
Flush-mounting, horizontal mounting	-	MK2430H-12	B95100024
Surface mounting	12/1	MK2430A-11	B 9510 0035
	-	MK2430A-12	B 9510 0036

Accessories

Type designation	Type	Art. No.	Art. No.
Parameterisation software	TMK-SET		as Internet download
MK2430-mounting kit, complete			B 9510 1000

Suitable system components

Type designation	Type	Art. No.
Power supply	AN450	B 924 201

LINETRAXX® CMS460-D4-2

Three phase loads monitoring

The CMS460-D4-2 is a device for load monitoring with 3-phase insulating transformers. It calculates the maximum of the load current of the three input channels and gives it as a % value, compared with the nominal transformer load current. The current on the three input channels is available on the BMS bus; also the load in % of the nominal transformer load current is available on channel 4. If the nominal load is reached or exceeded, then an alarm will be generated on channel 4 on the BMS bus and the relay will be activated. The measured currents can be analyzed for harmonics.

Features:

- Three r.m.s. measuring channels for the three load currents of three phase transformers
- Calculation of the maximum load of the three measured values
- Selectable nominal transformer load current 1 A ... 32 A (63 A)
- STW2/STW3/STW4 CTs selectable
- Response ranges 1 A...32 A (63 A) (42...2000 Hz)
- Alarm on channel 4 if 100 % of transformer load current is reached or exceeded on at least one of the channels 1...3
- Adjustable time delays
- History memory with date and time stamp for 300 data records/channel
- Data logger for 300 data records/channel
- Analysis of the harmonics, THD
- Two alarm relays with one changeover contact each
- N/O or N/C operation and fault memory selectable
- Connection for external test and reset button
- Backlit graphical display (7-segment display) and alarm LEDs
- Data exchange via BMS bus
- Password protection for device setting
- RoHS compliant

Standards:

DIN VDE 0100-710 (VDE 0100-710), DIN VDE 0100-718 (VDE 0100-718), ÖVE/ÖNORM E 8007, IEC 60364-7-710



LINETRAXX® CMS460-D4-2

Insulation coordination acc. to IEC 60664-1/IEC 60664-3

Rated impulse voltage/pollution degree	4 kV/3
Supply voltage	see ordering information

Measuring circuit

Number of measuring channels	3
External measuring current transformer	STW2/STW3/STW4
Measuring range	1 A...110 A
Rated operating current I_{n2} (alarm)	1...63 A (1 A overcurrent)*
Start-up delay t (start-up) per device	0...99 s (3 s)*

Displays, memory

LEDs	ON/ALARM
LC display	backlit graphical display
History memory	300 data records
Data logger	300 data records per measuring channel
Language	D, GB, F (GB)*

Inputs/outputs

Test/reset button	internal/external
-------------------	-------------------

Interface

Interface/protocol	RS-485/BMS
Baud rate	9.6 kbit/s
Cable length	≤ 1200 m
Cable (twisted in pairs, one end of shield connected to PE) recommended:	J-Y(St)Y min. 2x0.8
Terminating resistor	120 Ω (0.25 W) connectable via DIP switch
Device address, BMS bus	1...90 (2)*

Switching elements

Number	2 x 1 changeover contact
--------	--------------------------

Environment/EMC

EMC	IEC 61326-1
Operating temperature	0...+55 °C

() * factory setting

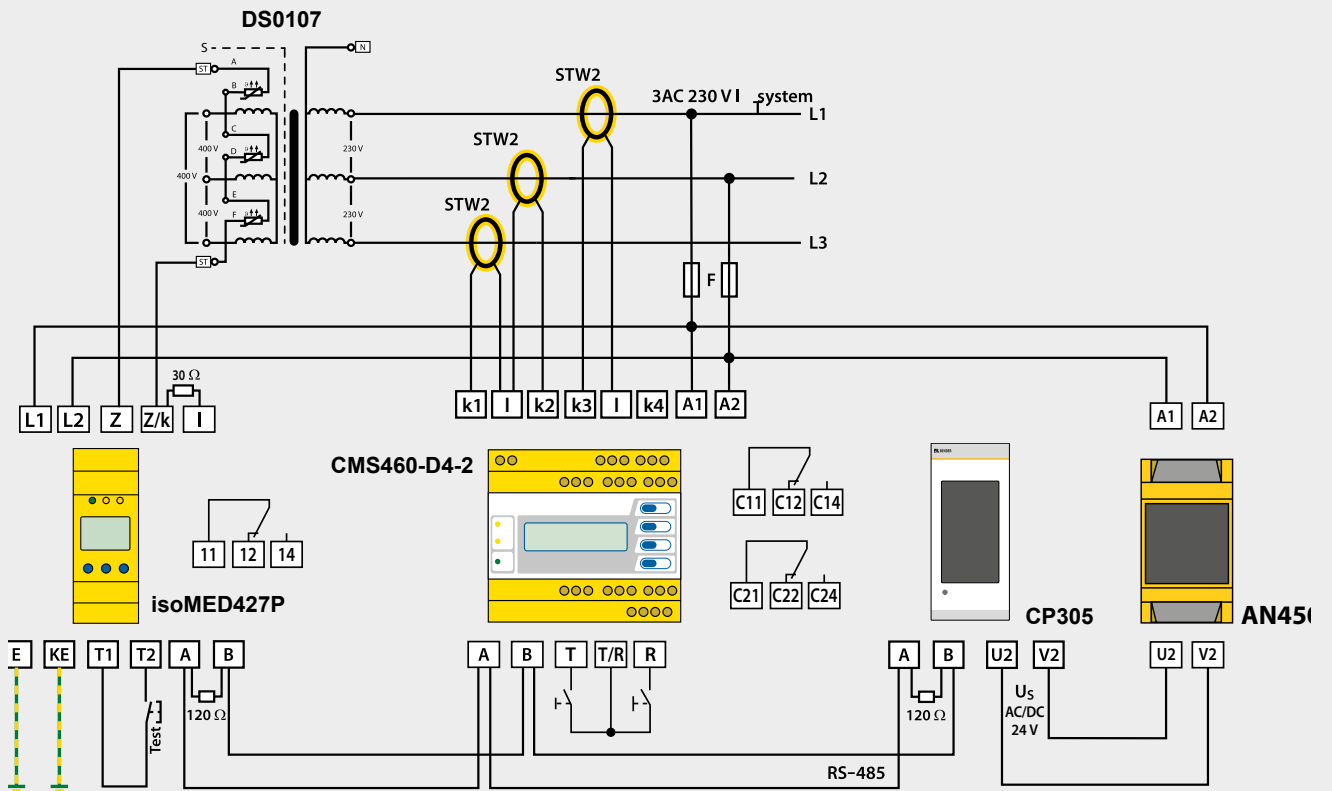

Wiring diagram isoMED427P/CMS460-D4-2

Ordering details

Supply voltage U_s	Type	Art. No.
100...240 V	CMS460-D4-2	B 9405 3030

Suitable system components

Type designation	Type	Art. No.
Current transformer	STW2	B 942 709
Current transformer	STW3	B 980 21000
Current transformer	STW4	B 980 21001
Temperature sensor	ES0107	B 924 186
Power supply	AN450	B 924 201

COMTRAXX®

The turnkey solution from Bender

The COMTRAXX® CP9xx is more than just an alarm indicator and operator panel. It is a control and information centre in hospitals. It allows users to switch devices on and off centrally, regulate the room climate, adjust the light with precision, switch luminous door warning signs on or off, check the level of medical gases among many other things. In combination with the measuring devices and

applications from Bender, the COMTRAXX® CP9xx can also indicate whether and where there is a fault in the electrical system and inform the staff what to do. Thanks to consistent and intelligent networking, the hospital's technical control centre is informed simultaneously in the event of a fault. This also means that the COMTRAXX® CP9xx is an important step in digitalisation towards Hospital 4.0.

What are the functions of the COMTRAXX® CP9xx?

- Switch and control devices centrally
- Monitor individual devices and controls
- Monitor and switch the power supply
- Report faults
- Request support

Where can the COMTRAXX® CP9xx be used?

- **Nurses' station:** Air conditioning, medical gases, luminous door warning signs, timer, alarm function (acoustic and visual), power supply, etc.
- **Operating theatre:** Lighting, operating table controls, climate/room air, luminous door warning signs, blinds, timer, system monitoring, alarm function (acoustic and visual), etc.
- **Intensive care unit:** Lighting, climate, device functions, medical gases, luminous door warning signs, blinds, timer, alarm function (acoustic and visual), etc.
- **Operating theatre coordination, recovery room, etc:** Monitoring incl. alarm function (acoustic and visual), etc.
- **Technical control centre:** System monitoring, common alarm, remote access, etc.

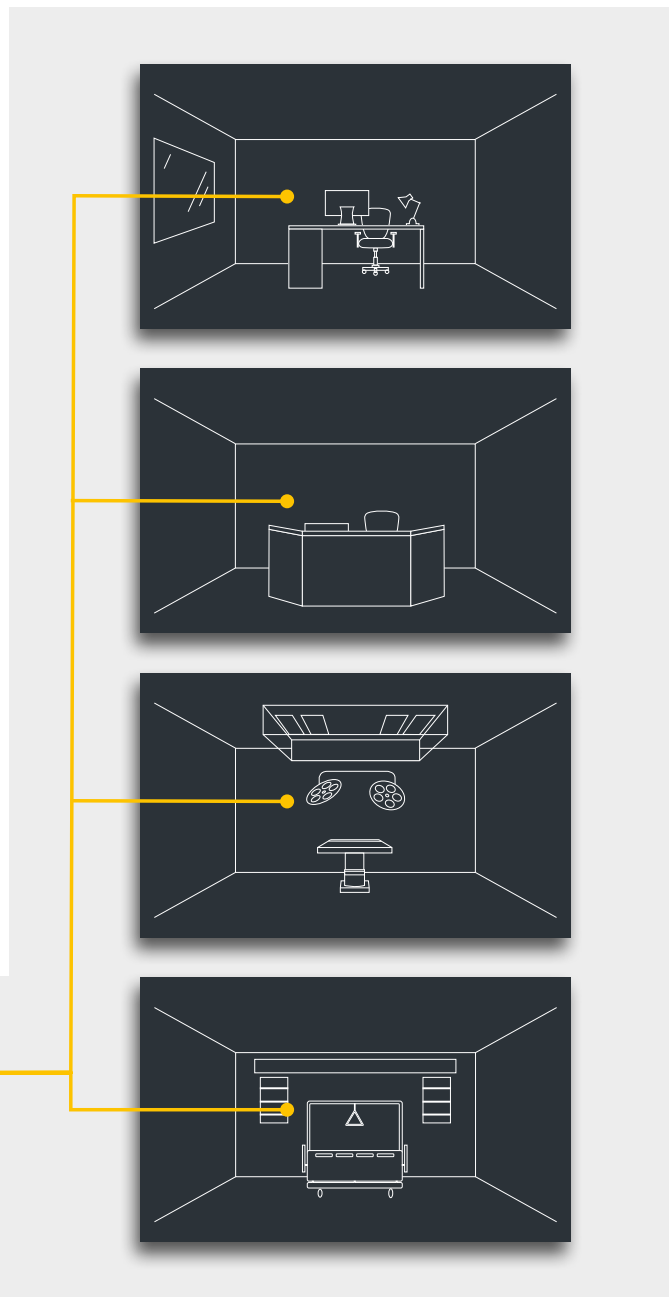

Flexible and individual solutions

Not every hospital is the same. Bender has many years of experience with alarm indicator and operator panels in medical locations. Based on the feedback and wishes of the customers, the COMTRAXX® CP9xx is a device with which a wide variety of customer solutions are possible. Instead of switches and small displays for one room, we offer a turnkey solution for operating theatres, intensive care units or nurses' stations as well as for the technical control centre. The modern design and innovative operating concept of the

COMTRAXX® CP9xx makes it even more suited for use as a control and information centre. The COMTRAXX® CP9xx can be configured individually for each application. The glass surface and design can also be tailored to the customer's wishes.

Examples:

- Printing of an individual logo
- Adapting the appearance to the interior design of the hospital



COMTRAXX® CP907-G
The little helper

The compact design of the CP907 makes it ideal for use as an information terminal which includes light control at nurses' stations or intensive care beds. It can be connected to the building management system by means of an RJ45 cable.



COMTRAXX® CP915-G & CP924-G
The hygienic and elegant one

Ideal for group-2 rooms. All necessary functions for room control can be integrated and are displayed in a clear way for the user. The uniform glass surface has no edges, which basically prevents dirt from adhering to it.



COMTRAXX® CP921-F
The flexible friend

Used wherever there are special installation requirements, for example when installation size and depth are predefined. The CP921-F is the best option for retrofitting/modernisation measures.



COMTRAXX® CP915-H & CP924-H
The big all-rounder

This hybrid solution combines all features of the COMTRAXX® CP9xx with necessary third-party devices, such as operating table controls. All important functions and controls are in one place. This central, clearly arranged information and operating unit enables medical staff to keep track of everything.



CP924-E
Essential 24" Control Panel for ORs

This theatre control panel allows all important devices in the operating theatre to be controlled and monitored. In addition, all condition information of devices is clearly displayed.

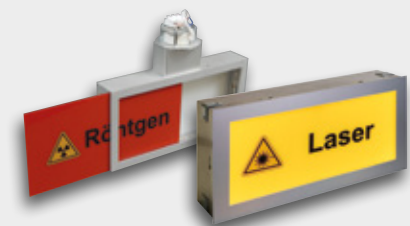

Illuminated door signs
Various types of enclosures

These display panels are often located above doors where it is necessary to indicate whether, for example, a room is occupied or in use and access may not be desired. These panels are often used in hospitals as well as in industrial or public buildings. The AT panels can be equipped with different coloured lenses and texts. Various types : Flush-mounted enclosure with projecting front plat, Surface-mounted enclosure and Ceiling enclosure

ATICS®

transfer switching and monitoring devices

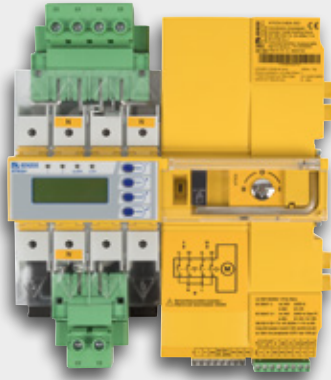

Transfer switching devices, 2 pole

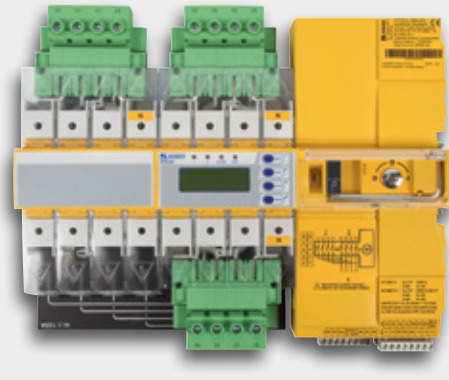

Automatic switching device for safety power supplies, 4 pole

ATICS®, the safest and most compact all-in-one automatic transfer switching device in the world for safety-relevant areas and medical locations.

Power supplies for sensitive equipment must function safely and reliably even under fault conditions. The ATICS® switching devices provide all functions for changeover between two independent power supplies. ATICS® has been developed consistently according to the Functional Safety standards (SIL 2) guarantee highest reliability. The switching device is perfectly suitable for the power supply in safety-relevant areas, e.g.

- Group 2 medical locations according to IEC 60364-7-710 and DIN VDE 0100-710 (VDE 0100-710)
- Emergency power supplies
- Heating, air conditioning, ventilation, cooling
- EDP, computer centres
- Fire extinguishing and sprinkler systems

Convincing advantages:

- All-in-one: Integration of switch disconnector and control
- Functional safety SIL 2
- Safe operation
- Switch disconnector contacts of robust design
- Mechanical locking
- Manual operation directly on the device
- Certification by TÜV SÜD
- Perfectly suitable for space-saving installation/retrofitting
- Convenient installation and commissioning
- Excellent communication and parameterisation options
- Plug connectors and optional bypass switch
- Uninterrupted maintenance
- Safe separation

IEC 60364-7-710.536.101 requires a „safe separation“ between systems as defined in IEC 60364-5-536.2.2.3, which does not allow semiconductor devices to be used as isolating devices.

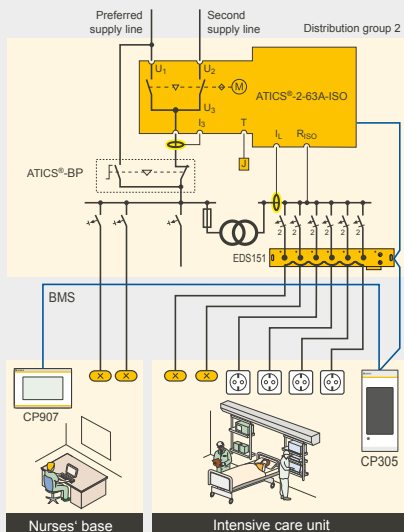

Changeover for intensive care units with integrated insulation fault location system (EDS) and bypass-switch

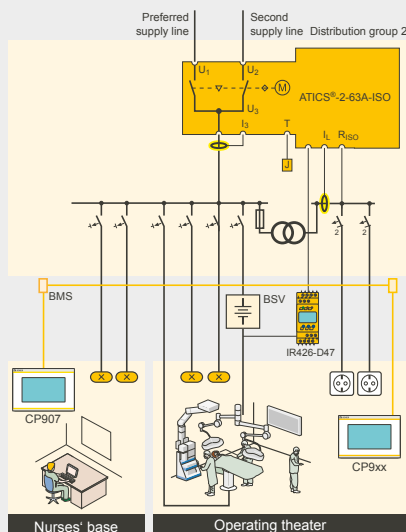

Changeover for operating theatres with operating theatre lights ISOMETER®

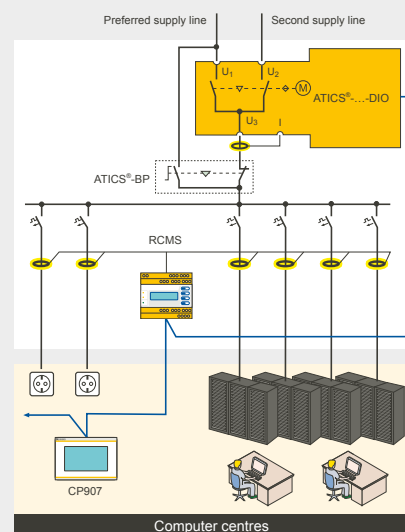

Changeover for safety-relevant environments with additional RCMS residual current monitoring system

Ordering information

Designation	Rated operational current I_e	Scope of delivery	Type	Art. No.
2-pole switching and monitoring device	AC 63 A	1 x STW2, 1 x STW3, bridge, terminal cover, auxiliary contacts	ATICS-2-63A-ISO	B 9205 7202
	AC 80 A	1 x STW2, 1 x STW3, bridge, terminal cover, auxiliary contacts	ATICS-2-80A-ISO	B 9205 7203
2-pole switching device	AC 63 A	1 x STW3, bridge, connectors, terminal cover	ATICS-2-63A-DIO	B 9205 7212
	AC 80 A	1 x STW3, bridge, connectors, terminal cover	ATICS-2-80A-DIO	B 9205 7213
4-pole switching device	AC 80 A	3 x STW3, bridge, connectors, terminal cover	ATICS-4-80A-DIO	B 9205 7222
	AC 125 A	3 x STW4, bridge, connectors, terminal cover	ATICS-4-125A-DIO	B 9205 7223
	AC 160 A	3 x STW4, bridge, terminal cover	ATICS-4-160A-DIO	B 9205 7224
Bypass switch set	AC 63 A	Bridge, terminal cover, auxiliary contacts, LEDs green/red	ATICS-BP-3-63A-SET	B 9205 7252
	AC 80 A	Bridge, terminal cover, auxiliary contacts, LEDs green/red	ATICS-BP-3-80A-SET	B 9205 7253

IT System Distribution Boards for Operating Theatre and Intensive Care



S-IPS-F/EDS with ATICS® Automatic changeover and monitoring device

IT System Distribution Boards

S-IPS-F series

Distribution boards are equipped with an isolating transformer as well as with a changeover and monitoring module including all necessary monitoring components as to IEC 60364-7-710 and DIN VDE 100-710 for IT systems:

- Changeover device and voltage monitoring
- Insulation monitoring
- Load and temperature monitoring

The secondary side of the isolating transformer is equipped with at least 6 two-pole circuit breakers. Group 2 sockets are being connected to these. In order to reduce or avoid noise disturbance by air circulating fans, waste heat is conducted by free convection.

Device features

- Components
 - Automatic transfer switching device ATICS® including monitoring of i.e.:
 - Voltage of incoming supply
 - Output voltage
 - Correct operating times
 - Changeover times
 - Insulation resistance
 - Load current
 - Transformer temperature
 - At least 6 two-pole MCBs
 - Isolating transformer (3150 VA – 10000 VA)
- Variable changeover time $t \leq 0.5 \dots 15$ s
- Exchange of information by means of bus technology
- Connection facility for remote alarm indicator and operator panels CP305 / CP9xx
- Sheet steel housing
- Designed in accordance with the requirements of applicable standards
- Voluntary certification of changeover device by the independent German technical service, testing and inspection organisation (TÜV)

IT System Distribution Boards

S-IPS-F/EDS series

Distribution boards are equipped with an isolating transformer as well as with a changeover and monitoring module including all necessary monitoring components as to IEC 60364-7-710 and DIN VDE 100-710 for IT systems:

- Changeover device and voltage monitoring
- Insulation monitoring
- Load and temperature monitoring
- Insulation fault locator
- Bypass Switch

The secondary side of the isolating transformer is equipped with at least 6 two-pole circuit breakers. Group 2 sockets are being connected to these. In order to reduce or avoid noise disturbance by air circulating fans, waste heat is conducted by free convection.

Device features:

- Components
 - Automatic transfer switching device ATICS® including monitoring of i.e.:
 - Voltage of incoming supply
 - Output voltage
 - Correct operating times
 - Changeover times
 - Insulation resistance
 - Load current
 - Transformer temperature
 - At least 6 two-pole MCBs
 - Insulation fault monitoring device (EDS)
 - Bypass switch
 - Isolating transformer (3150 VA – 10000 VA)
- Variable changeover time $t \leq 0.5 \dots 15$ s
- Exchange of information by means of bus technology
- Connection facility for remote alarm and operator panels CP305 / CP9xx
- Sheet steel housing
- Designed in accordance with the requirements of applicable standards
- Voluntary certification of changeover device by the independent German technical service, testing and inspection organisation (TÜV)

EDS 151

Insulation fault location system

The insulation fault locator EDS151 in conjunction with the ISOMETER® isoMED427P or the locating current injector PGH, are designed for insulation fault location in unearthed power supplies (IT systems). The locating current pulse generated by the ISOMETER® isoMED427P or the locating current injector PGH are detected using the integrated measuring current transformers and evaluated by insulation fault locators. The integration of six measuring current transformers in an EDS151 permits all current-carrying conductors of an outgoing line to be routed through. The response time for an alarm message inclusively indication on the respective display device is max. 8 s (e.g. CP305 / CP9xx). A total of 88 EDS151 devices can be connected via an RS-485 interface (BMS protocol). Hence, up to 528 circuits can be monitored. Activities on the BMS bus are indicated by an alarm LED.

Device features

- Insulation fault location in AC, AC/DC and DC IT systems
- 6 measuring channels with measuring current transformer per EDS151
- Up to 528 measuring channels can be combined by the BMS bus in the IT system being monitored: 88 x 6 measuring channels
- Response sensitivity EDS151: 0.5 mA
- A response time of up to 8 s in the AC system acc. to IEC 61557-9
- RS-485 interface with BMS protocol
- BMS address range 3...90
- Cyclical self test

Standards

The ISOSCAN® EDS151 complies with the requirements of the device standards: IEC 61557-9.



ISOSCAN® EDS151

Ordering details

Supply voltage U_s		Type	Art. No.
AC	DC		
17...24 V, 50...60 Hz	14...28 V	EDS151	B 9108 0101

Suitable system components

Type designation	Type	Art. No.
Power supply unit	AN450	B 924 201

Power supply units

AN450

The power supply unit AN450 is designed to supply Bender devices with a supply voltage of AC 20 V and a total power consumption of maximum 9 VA. A maximum of 3 alarm indicator and test combinations MK2430/MK800 or 6 EDS151 insulation fault locators can be supplied, for example.

Standards:

The AN450 series complies with the requirements of the device standards:
DIN EN 61558-1 (VDE 0570-1) and IEC 61558-1.



AN450

Ordering details

Output voltage		Type	Art. No.
DC	AC		
-	20 V, 50...60 Hz	AN450	B 924 201

EDS441

Insulation fault location system

Basically, every EDS441 system consists of the following components: the PGH test device, the CP305 control and indicating device, and one or several EDS441 insulation fault locators with the accompanying

measuring current transformers. Information exchange between the EDS441 insulation fault locators and the remote alarm indicator and test combination MK2430 takes place via a two wire connection.



ISOSCAN® EDS441-L



CTAC series

EDS441-L:

The insulation fault locators ISOSCAN® EDS44x are used in connection with the ISOMETER® iso685-D-P or the locating current injector PGH to locate insulation faults in unearthed power supply systems (IT systems). They detect locating current signals generated by the insulation monitoring device iso685-D-P or the locating current injector PGH and evaluate them correspondingly. Up to 12 measuring current transformers can be connected to an EDS44x. In total, up to 50 insulation fault locators can be connected via an RS-485 interface (BS bus protocol) and thereby up to 600 outgoing circuits can be monitored.

CTAC series:

The highly sensitive CTAC series measuring current transformers in combination with RCM or RCMS series residual current monitors and evaluators convert AC currents into an evaluable measurement signal. They are also suitable for use in insulation fault location systems for IT systems (EDS). The current transformers measure the locating current generated by a PGH locating current injector or an ISOMETER® iso685. In combination with EDS series insulation fault locators, the locating current is converted into an evaluable measurement signal. The connection to the respective devices is made via a two-wire cable.

Ordering details

Supply voltage U_s		Type	Art. No.
AC/DC	DC		
-	DC 24 V	EDS441-S-1	B91080204
-	DC 24 V	EDS441W-S-1	B91080204W
AC/DC 24...240 V	-	EDS441-L-4	B91080205
AC/DC 24...240 V	-	EDS441W-L-4	B91080205W
AC/DC 24...240 V	-	EDS441-LAB-4	B91080207
AC/DC 24...240 V	-	EDS441W-LAB-4	B91080207W

Measuring current transformer for EDS441

Design type	Internal diameter/mm	Type	Art. No.
circular	20	CTAC20/01	B98110006
	35	CTAC35/01	B98110008

Alternative measuring current transformer from the Bender program

Design type	Internal diameter/mm	Type	Art. No.
circular	10	W10/8000	B911759
	35	W1-35/8000	B911756
circular, 6-fold	10	W10/8000-6	B911900
split-core	20 x 30	WS20x30/8000	B911764
	50 x 80	WS50x80/8000	B911757

For further information regarding the measuring current transformers, refer to the respective data sheets.

Wiring diagram

Insulation fault location system

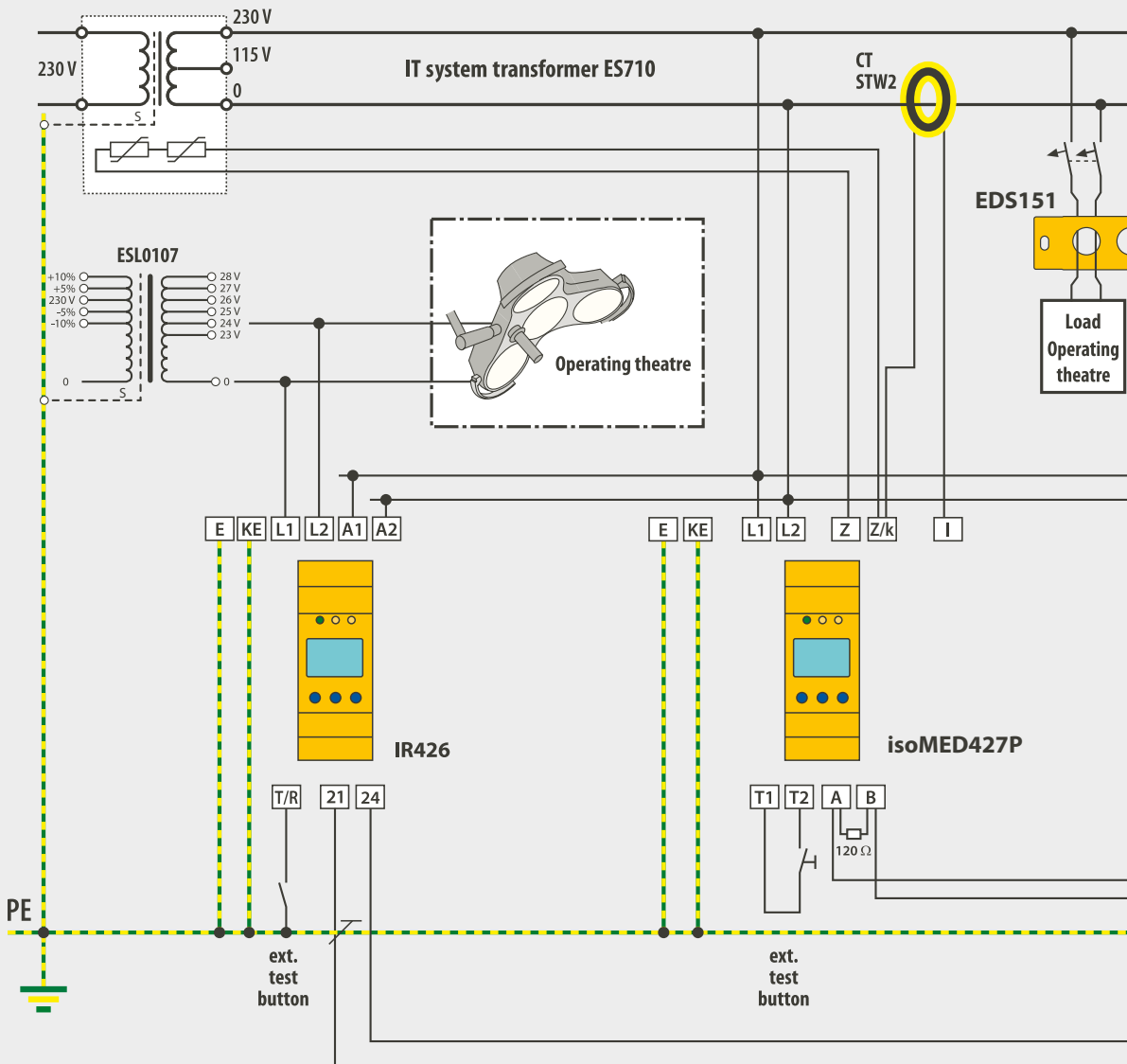

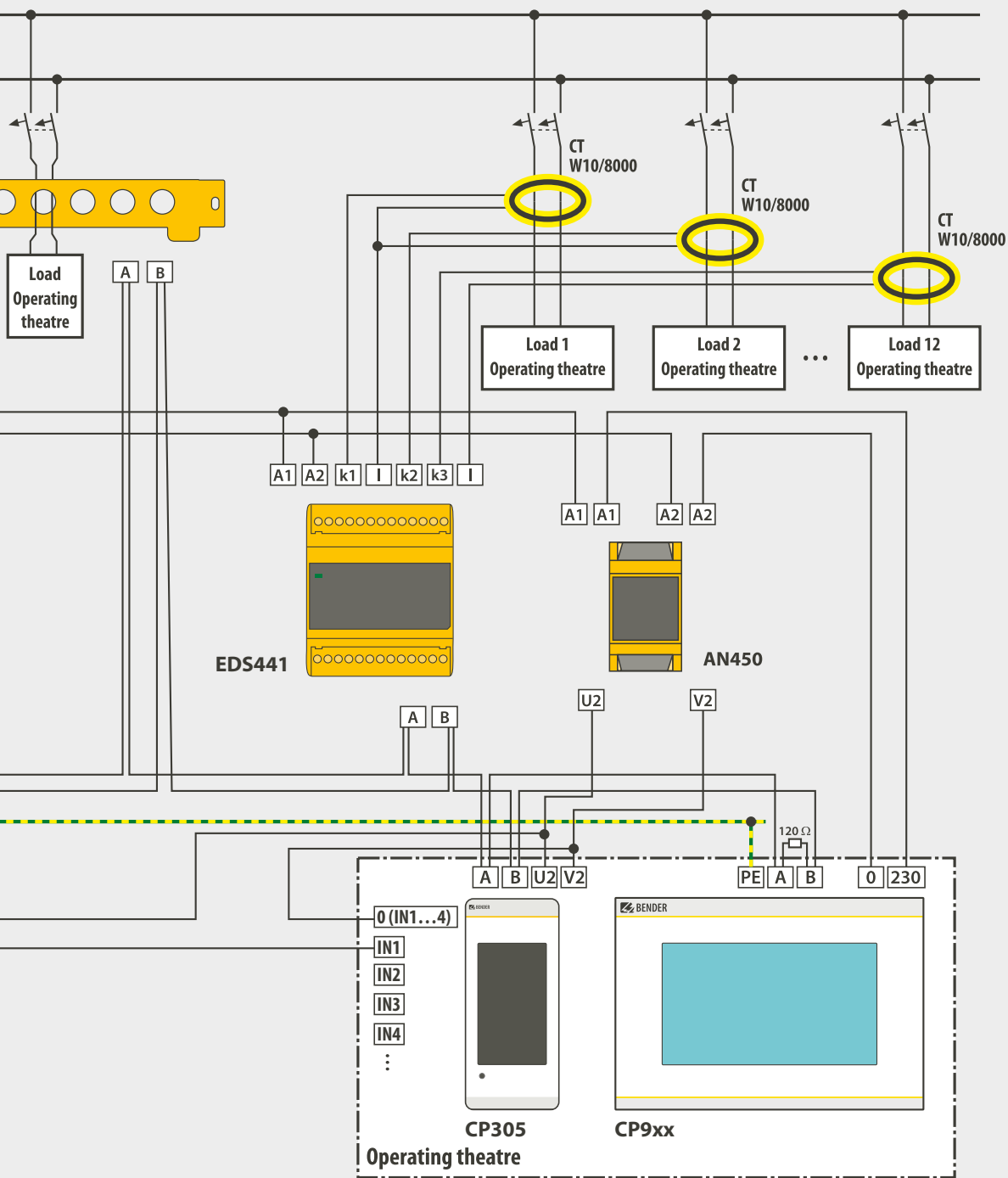

ES710

Single-phase isolating transformer

Isolating transformers of the ES710 series for the power supply of single-phase IT systems in accordance with IEC 60364-7- 710 and DIN VDE 0100-710 (VDE 0100-710). A static screen is installed between the primary and secondary windings, which is connected to an isolated terminal. The mounting angles are isolated from the transformer core.

Features:

- The single-phase isolating transformers meet the requirements of the following standards: IEC 60364-7-710, DIN VDE 0100-710, IEC 61558-1, DIN EN 61558-1 (VDE 0570-1), IEC 61558-2-15, DIN EN 61558-2-15 (VDE 0570-2-15).
- Rated power 3.15...10 kVA
- Built-in temperature sensors
- Low noise level < 35 dB (A)
- High overload capability
- VDE ENEC mark

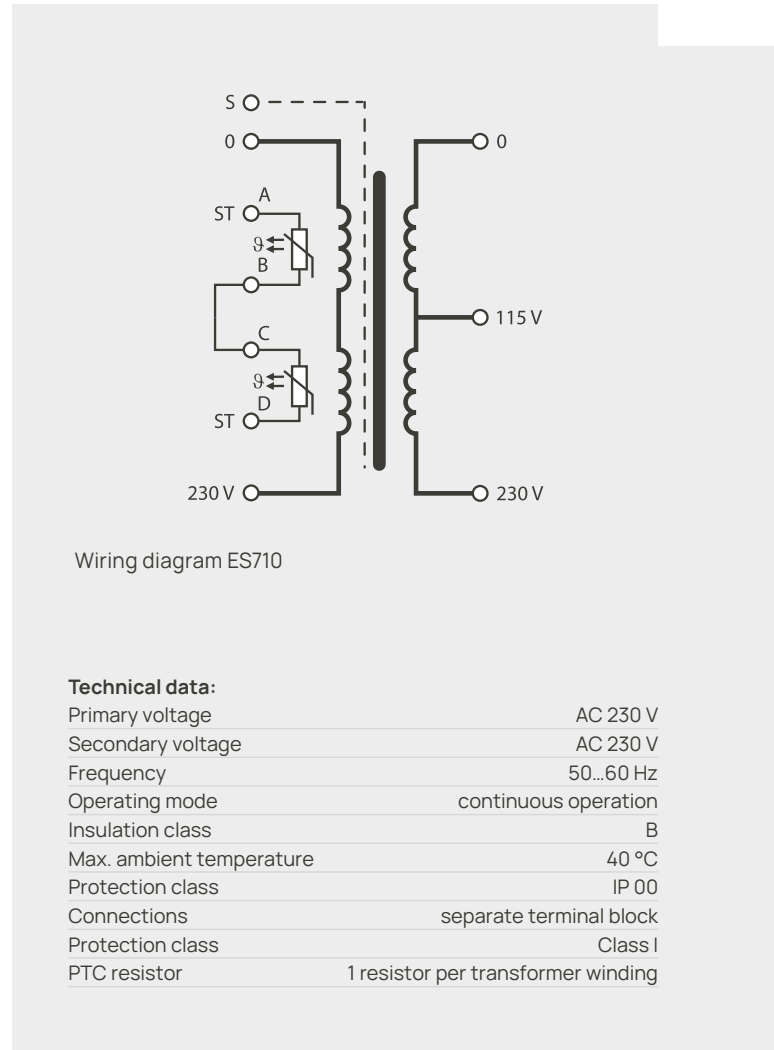

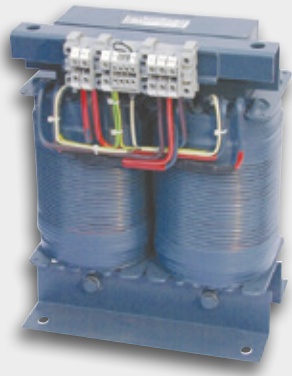

ES710

Type series

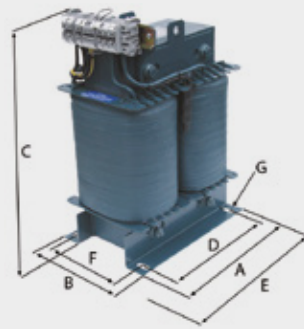

S series

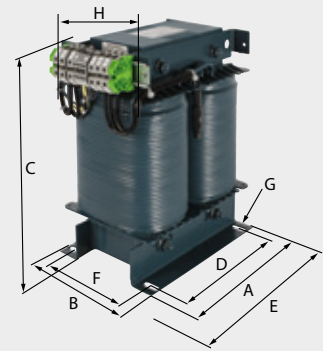

SN-GL series

Dimensions, weight, ordering details

S series

Nominal power kVA	Measures in mm							Total weight kg	Type	Art. No.
	A	B	C	D	E	F	G			
3.15	240	230	325	200	200	160	11	49	ES710/3150	B924211
4	280	220	370	240	190	150	11	59	ES710/4000	B924212
5	280	230	370	240	200	160	11	61	ES710/5000	B924213
6.3	280	245	370	240	215	175	11	65	ES710/6300	B924214
8	280	260	370	240	230	190	11	74	ES710/8000	B924215
10	320	280	420	270	233	193	13	85	ES710/10000	B 924216

SN-GL series

Nominal power kVA	Measures in mm							Total weight kg	Type	Art. No.
	A	B	C	D	E	F	G			
3.15	240	230	325	200	180	145	11	49	ES710/3150-GL	B92090121
4	280	200	370	240	150	115	11	59	ES710/4000-GL	B92090122
5	280	210	370	240	160	125	11	61	ES710/5000-GL	B92090123
6.3	280	225	370	240	175	140	11	65	ES710/6300-GL	B92090124
8	280	240	370	240	190	155	11	74	ES710/8000-GL	B92090125
10	280	255	370	240	205	170	11	85	ES710/10000-GL	B92090126

Enclosures for transformers

Measures in mm								Total weight kg	Type	Art.-No.
A	B	C	D	E	F	G	H			
430	380	500	385	420	450	∅ 37.5	∅ 20.5	16	ESDS0107-1	B 924 673

DS0107

Three-phase isolating transformer

Isolating transformers of the DS0107 series for the power supply of three-phase IT systems in accordance with IEC 60364-7-710. A static screen is installed between the primary and secondary windings, which is connected to an isolated terminal. The mounting angles are isolated from the transformer core.

Features:

- The three-phase isolating transformers meet the requirements of the following standards: IEC 60364-7-710, IEC 61558-1, DIN EN 61558-1 (VDE 0570-1), IEC 61558-2-15, DIN EN 61558-2-15 (VDE 0570-2-15).
- Rated power 3.15...10 kVA
- Built-in temperature sensors

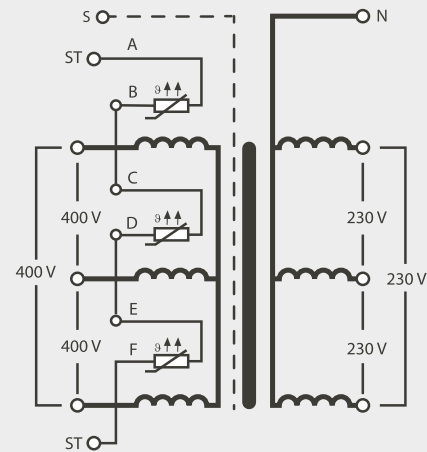

Wiring diagram DS0107

Technical data:

Primary voltage	3AC 400 V
Secondary voltage	3NAC 230/127 V
Frequency	50...60 Hz
Operating mode	continuous operation
Insulation class	B
Max. ambient temperature	40 °C
Protection class	IP 00
Connections	separate terminal block
Protection class	Class I
PTC resistor	1 resistor per transformer winding

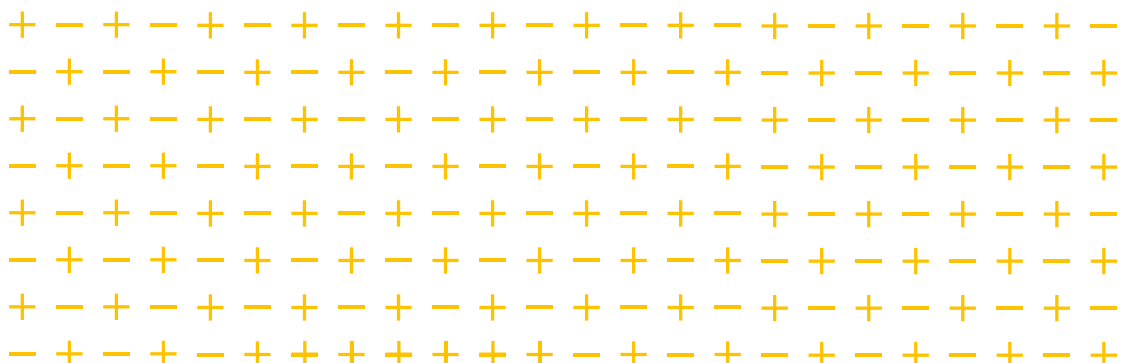
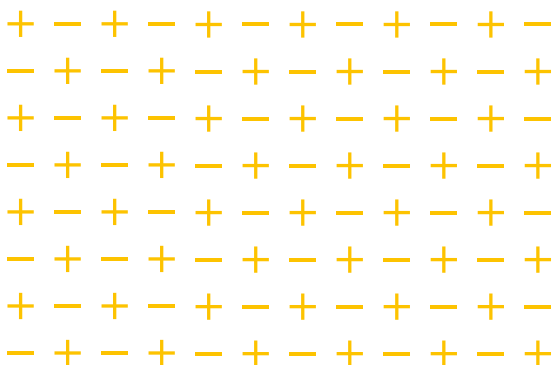

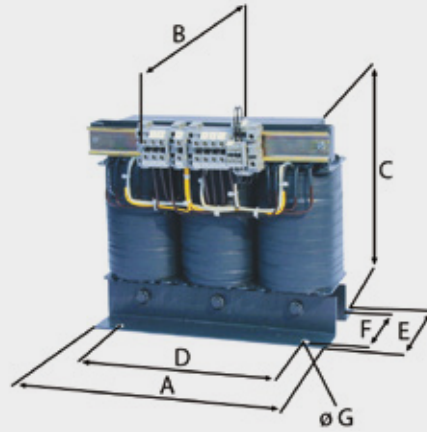
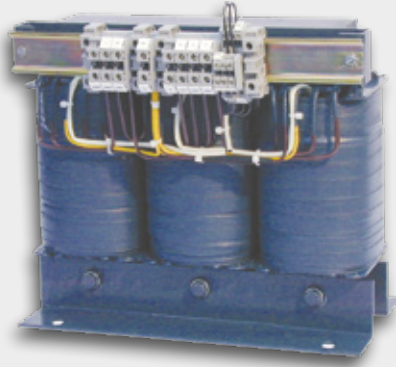

DS0107

Dimensions, weight, ordering details

Nominal power kVA	Measures in mm							Total weight kg	Type	Art.-No.
	A	B	C	D	E	F	G			
3.15	360	210	325	310	170	135	11	63	DS0107/3150	B 924 106
4	360	225	325	310	185	150	11	70	DS0107/4000	B 924 121
5	360	240	325	310	200	165	11	77	DS0107/5000	B 924 112
6.3	420	230	370	370	200	160	11	97	DS0107/6300	B 924 107
8	420	245	370	370	215	175	11	107	DS0107/8000	B 924 628
10	420	260	370	370	230	190	11	130	DS0107/10000	B 924 672

Enclosures for transformers

Measures in mm								Total weight kg	Type	Art.-No.
A	B	C	D	E	F	G	H			
430	380	500	385	420	450	∅ 37.5	∅ 20.5	16	ESDS0107-1	B 924 673 ¹⁾
600	420	490	555	460	490	∅ 50.5	∅ 20.5	23	ESDS0107-2	B 924 674 ²⁾

1) for DS0107/3150...DS0107/5000 – 2) for DS0107/6300...DS0107/10000

LINETRAXX® Power Quality and Energy Measurement

For transparency in electrical installations



Power Quality and Energy Measurement



COMTRAXX® CP9...-I

Acquisition of relevant data for energy management and basic power quality measurands.

The PEM digital universal measuring instruments are used to record and display electrical quantities of an electric power system. The scope of the measurements ranges from currents and voltages, energy consumption and power up to the total distortion factor for assessing the voltage quality.

Convincing advantages

The COMTRAXX® CP907-I series condition monitor collects and evaluates measured data.

- One platform for uniform operation and parameter setting of a wide variety of devices
- Intuitive operation
- Interactive help systems instead of device manuals
- Automatic adaptation to your system
- Guidance for fault elimination and immunisation
- Filtering of the relevant information for the respective user

COMTRAXX®

Display size	Supply voltage	Enclosure	Display unit glass, tempered	Type	Art. No.
7" (17.6 cm)	DC 24 V, < 15 W	Flush-mounting enclosure	white	CP907-I	B95061031
		Control cabinet door mounting	white		B95061032
15.6" (38.6 cm)	AC 100...240 V, < 30 W	Flush-mounting enclosure	white	CP915-I	B95061033
			grey		B95061034

Power Quality

Voltage inputs (L1, L2, L3)	Supply voltage	Interface	Current input	Type	Art. No.
		Modbus RTU			
TN and TT system (earthed): AC 230/400...400/690 V, CAT III 600 V IT system (unearthed): AC 400...480 V, CAT III 300 V / AC 500...690 V, CAT II 1000 V	95...250 V; DC, AC 47...440 Hz	■	5 A / 1 A	PEM353	B93100355
		■		PEM353-P	B93100354
		■		PEM353-N	B93100353

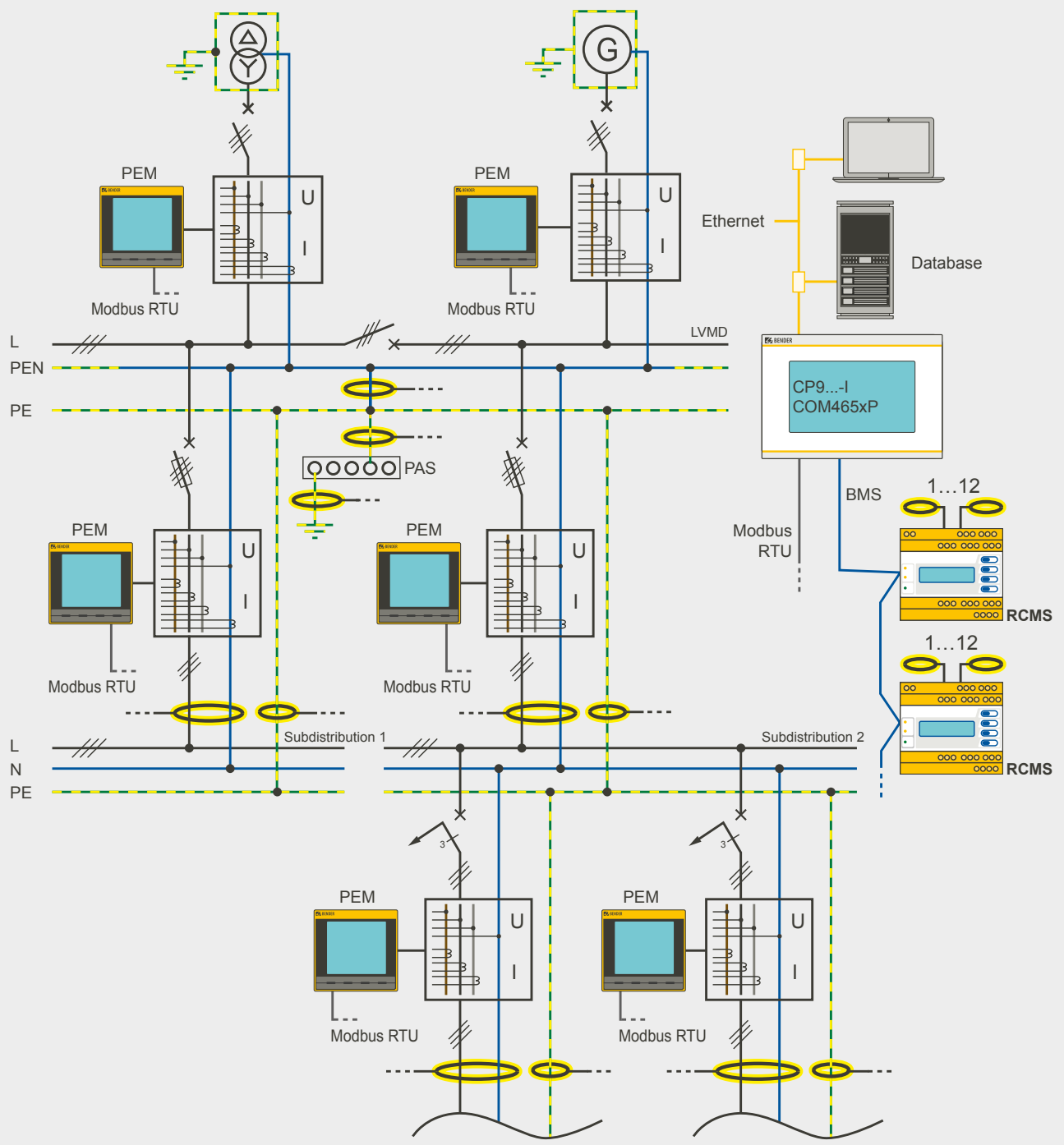

Application diagram LINETRAXX ®

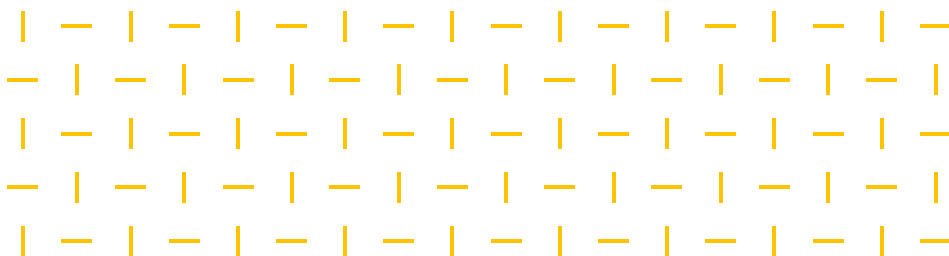

Bender communication solutions

The COM465IP is a Condition Monitor with gateway that converts data from the Bender system into the Modbus TCP protocol. The integrated web interface gives a perfect overview of the data from Bender systems on any personal computer, tablet or smartphone. Additional software installation is not required.

Features

- Condition Monitor for Bender systems
- Integrated modular gateway between Bender systems and TCP/IP enables remote access via LAN, WAN or the Internet
- Range of functions adjustable through function modules
- Ethernet (10/100 Mbit/s) for remote access via LAN, WAN or the Internet
- Support of devices connected to the internal or external BMS bus via BCOM, Modbus RTU or Modbus TCP

Your advantages

- Bidirectional Modbus TCP gateway
- Fast, simple parameter setting of all devices in the Bender system using a web browser
- Assignment of system-specific text codes for devices and measurement points
- E-mail notifications for alarms and system faults to different user groups
- Device failure monitoring
- Report function stores measured values and settings. Saved settings can be used for parameterisation of other devices. This means comparing previous and current settings is very simple and clear
- Fast, clear visualisation without requiring special programming skills to set it up. For example, measurements or alarms can be arranged and displayed on a building plan. Links along with the alarm status of the devices contained therein can be inserted into the different views



Ethernet gateway COMTRAXX® COM465IP

Web overview

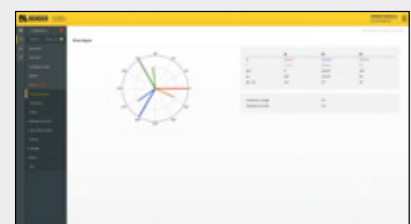
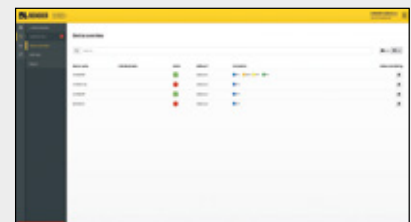
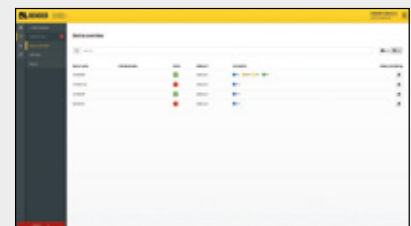

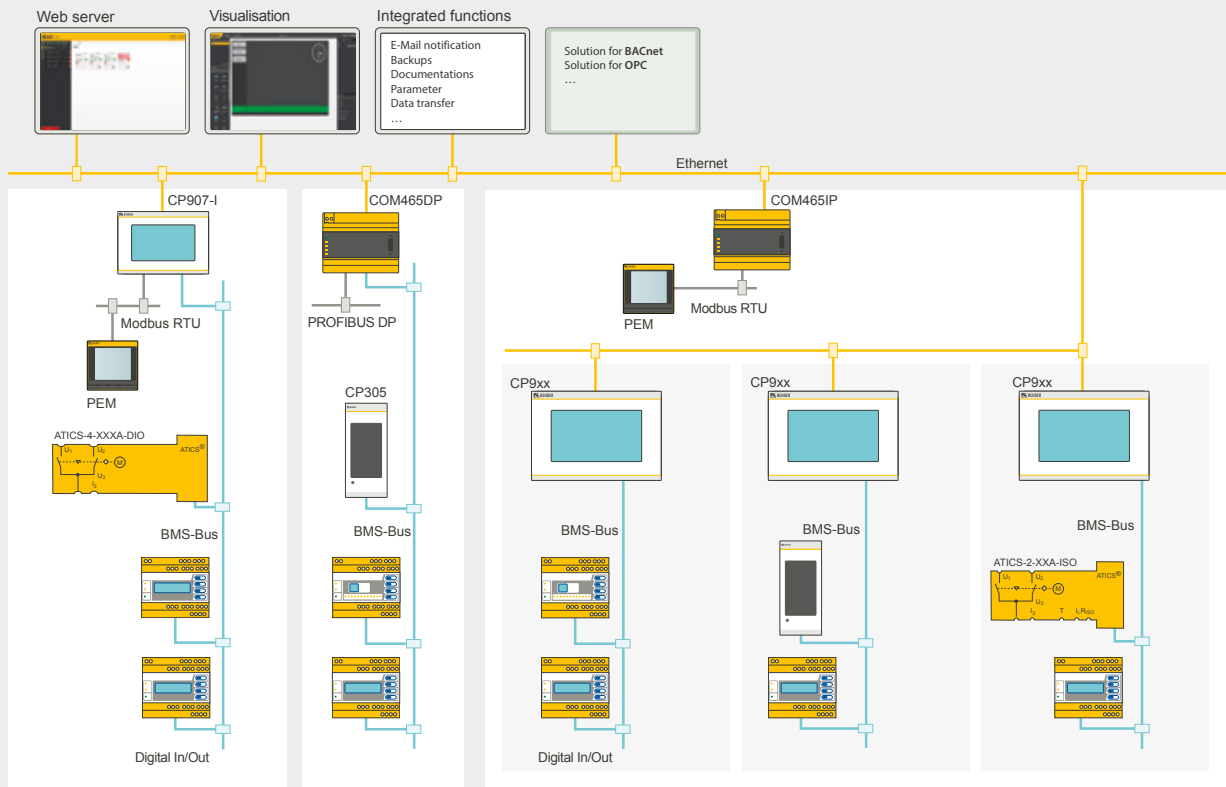

Communication possibilities with Bender systems and devices

Ordering information

Supply voltage/frequency range U_s		Power consumption	Application	Type	Art. no.
AC/DC	DC				
24...240 V, 50...60 Hz	-	$\leq 6.5 \text{ VA} / \leq 4 \text{ W}$	Condition Monitor with integrated gateway: Bender system/Ethernet	COM465IP-230V	B95061065
-	24 V	$\leq 3 \text{ W}$		COM465IP-24V	B95061066
24...240 V, 50...60 Hz	-	$\leq 6.5 \text{ VA} / \leq 4 \text{ W}$	Condition Monitor with integrated gateway: Bender system / PROFIBUS DP / Ethernet	COM465DP-230V	B95061060
-	24 V	$\leq 3 \text{ W}$		COM465DP-24V	B95061061

Optional package

Application	Function module (software licence)	Art. no.
Individual text messages for all devices/channels, device failure monitoring, e-mail in the event of an alarm	Function module A	B 7506 1011
Modbus TCP server for max. 98 * 139 BMS nodes as well as BCOM and universal measuring devices, SNMP server	Function module B	B 7506 1012
Parameter setting of BMS devices as well as BCOM and universal measuring devices	Function module C	B 7506 1013
Visualisation of Bender systems, system visualisation	Function module D	B 7506 1014
Virtual devices	Function module E	B 7506 1015
Integration of third-party devices	Function module F	B 7506 1016

Support during all stages – All-round service for your installation: remote, by telephone, on site

From planning to modernisation – Our extensive know-how is at your disposal during all project phases.

Furthermore, with our first-class service we guarantee maximum safety for your electrical installations. We offer services ranging from support over telephone to repairs and on-site service – with modern measuring devices and competent employees.

Be on the safe side:

- High availability of your installation thanks to fast reaction to fault messages
- Increased profitability of your capital expenditure (CapEx) via optimised maintenance processes
- Targeted operating expenditure (OpEx) due to reduced downtimes and shorter service visits

- Support for your predictive system monitoring and regular tests of your system/power quality/ monitoring devices
- Automatic control, analysis, correction, new settings/updates
- Competent assistance with changes of parameter settings and updates

Bender Remote Assist

Bender Remote Assist offers you support via remote access, high-quality service and advice for your challenging task consisting in ensuring consistent high safety in your systems.

Many service operations, fault eliminations but also analyses and controls can be carried out remotely – without the expense of time and money that an on-site visit of a technician implies.

This fast, efficient help and advice by our expert network allows the highest possible availability of your system.



Bender. Making your world safe.

Our world is networked on a global scale; it is digital, mobile and highly automated. And no matter whether in hospitals, in industry, inside or outside buildings, in power stations, in trains, underwater or underground: it never stands still and it is more dependent than ever on a reliable and, above all, safe electrical power supply.

And exactly that is our mission: We make electricity safe. With our technologies, we ensure that electricity is permanently available and guarantee faultless protection against the hazards of electric shock. We protect buildings, installations and devices, and therefore your investments and plans. But what we primarily protect are the lives of the people behind the electrical installations.

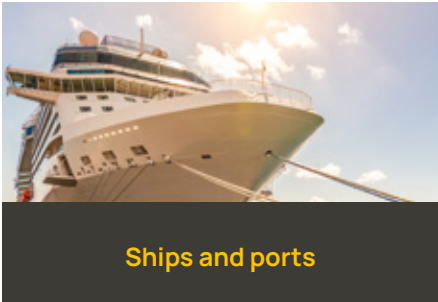

Some references for hospital equipment (Europe)

Country	City	Name
Austria	Bregenz	Landeskrankenhaus Bregenz
	Eisenstadt	Krankenhaus Barmherzige Brüder Eisenstadt
	Graz	LKH-Universitätsklinikum Graz
	Innsbruck	Universitätsklinikum Innsbruck
	Klagenfurt	Landeskrankenhaus Klagenfurt
	Linz	Allgemeines Krankenhaus der Stadt Linz Unfallkrankenhaus Linz Landes-Frauen- und Kinderklinik Landes-Nervenklinik Wagner Jauregg Allgemein öffentliches Krankenhaus Elisabethinen Linz
	Salzburg	Universitätsklinikum Salzburg
	Spittal/Drau	A.ö.Krankenhaus Spittal/Drau
	St. Pölten	Landesklinikum St. Pölten
	Wien	Allgemeines Krankenhaus der Stadt Wien Krankenhaus Göttlicher Heiland Unfallkrankenhaus Meidling Sozialmedizinisches Zentrum Ost - Donauspital
	Wr. Neustadt	Landesklinikum Wr. Neustadt
Belorussia	Gomel	Cardiological Center
	Minsk	Clinical City Hospital No. 10 Republican Hospital Transplantology Center of the Belorussian Public Health Ministry
Croatia	Split	Medical Centre
	Zagreb	Medical Centre
	Karlovac	General Hospital
	Virovitica	General Hospital
	Osijek	General Hospital
	Zagreb	Children's Hospital
Czech Republic	Brno	Faculty Hospital Brno Bohunice St. Anne's university hospital Brno
	Hradec Králové	Faculty Hospital Hradec Králové
	Jihlava	Hospital Jihlava
	Karlovy Vary	Hospital Karlovy Vary
	Nový Jičín	Hospital Nový Jičín
	Prag	FN Motol University Hospital

Country	City	Name
		
Motol Hospital		
Estonia	Kohtla-Järve	Ida-Viru Keskhaigla
	Tallinn	Põhja-Eesti Regionaalhaigla Ida-Tallinna Keskhaigla
	Tartu	Tartu Ülikooli Kliinikum
Germany	Berlin	Charite – Virchow Klinikum Berlin
	München	Uniklinikum München-Grohadern
	Hamburg	Unfallkrankenhaus Eppendorf-Hamburg
	Dresden	Universitätsklinikum Dresden
	Hannover	Medizinische Hochschule Hannover
	Magdeburg	Uniklinikum Magdeburg
Lithuania	Würzburg	Klinikum Würzburg
	Joniskis	Joniskis Hospital
	Klaipeda	Republic Hospital Klaipeda
	Siauliai	Siauliai Surgery Centre
	Vilnius	Children's Hospital of Santariskiu Klinikos
Norway	Bergen	Helse Bergen HF Haukeland Universitetssykehus
	Bødø	Nordlandssykehuset HF
	Drammen	Vestre Viken HF Sykehuset Buskerud
	Kristiansand	Sørlandets Sykehus HF Kristiansand
	Oslo	Oslo Universitetssykehus HF, Rikshospitalet Oslo Universitetssykehus HF, Radiumhospitalet Oslo Universitetssykehus HF, Ullevål Oslo Universitetssykehus HF, Aker Akershus Universitetssykehus HF
	Stavanger	Helse Stavanger HF
	Tønsberg	Sykehuset Vestfold HF
	Trondheim	St Olavs Hospital HF

Country	City	Name
Poland	Białystok	Uniwersytecki Szpital Kliniczny
	Bydgoszcz	Szpital Wojskowy
	Gdańsk	Centrum Medycyny Inwazyjnej UMG
	Jarocin	Szpital Powiatowy
	Lublin	SPSK nr 4
	Szczecin-Zdunowo	Szpital Specjalistyczny
	Warszawa	Szpital im. Św. Rodziny Szpital Praski Instytut Gruźlicy i Chorób Płuc Wojskowy Instytut Medyczny
	Zabrze	Śląskie Centrum Chorób Serca
	Żary	105. Szpital Wojskowy
Slovak Republic	Bánská Bystrica	Faculty Hospital with policlinic F.D. Roosevelta
	Dunajská Streda	Hospital Dunajská Streda
	Prešov	Faculty hospital Prešov
	Ružomberok	Hospital Ružomberok
	Žilina	Hospital with policlinic Žilina
Slovenia	Ljubljana	University Medical Centre Institute of Oncology Children's Hospital
	Maribor	University Medical Centre
	Celje	General Hospital
	Slovenj Gradec	General Hospital
	Jesenice	General Hospital
	Murska sobota	General Hospital
	Brežice	General Hospital
Sweden	Karlstad	Centralsjukhuset
	Linköping	TMC – Linköping Universitetet
	Göteborg	BIOC Bild och interventionscentrum Angereds närsjukhus
	Örebro	USÖ – Universitetssjukhuset i Örebro Örebro Sjukhus
	Jönköping	Länssjukhuset Ryhov
	Lindesberg	Lindesbergs lasarett
	Sundsvall	Sundsvalls Sjukhus. Operation
	Norrköping	Vrinnevisjukhuset
Switzerland	Basel	Universitätsspital Basel
	Luzern	Luzerner Kantonsspital Hirslanden Klinik St. Anna
	Bern	Inselspital Bern
	Grabs	Spital Grabs
	Männedorf	Spital Männedorf
	Winterthur	Kantonsspital Winterthur
	Zürich	Universitätsspital Zürich

Country	City	Name
UK	London	Royal Free Hospital
	Newcastle	Newcastle Royal Infirmary
	Edinburgh	Royal Infirmary of Edinburgh
	Birmingham	Birmingham PFI Hospital Good Hope Hospital
	Liverpool	Alder Hey Hospital Liverpool Heart & Chest Hospital
	Barrow-in-Furness	Furness General Hospital
	Manchester	Manchester Royal Infirmary
	Brighton	Royal Sussex County Hospital

Some references for hospital equipment (South and North America)

Country	City	Name
Argentina	Buenos Aires	Hospital Britanico
		Sanatorio Mater Dei
		Hospital Aleman
Brazil	Altamira	Hospital Geral De Altamira
	Belo Horizonte	Santa Casa De Misericordia De Belo Horizonte
	Brasilia	Hospital Daher Lago Sul
	Campo Grande	Hospital Regional Do Mato Grosso Do Sul
	Juazeiro Do Norte	Hospital Regional Do Cariri
	Manaus	Hospital Nilton Lins
	Recife	Hospital Geral Jayme Da Fonte
	Rio De Janeiro	Hospital Das Americas Hospital Quinta D'or
	Salvador	Hospital Aliança
	São Luiz	Hospital Dr Carlos Macieira
	São Paulo	Hospital Sirio Libanes Hospital Israelita Albert Einstein
	Teresina	Hospital Universitario Do Piaui
	Vitoria	Hospital Dorio Silva

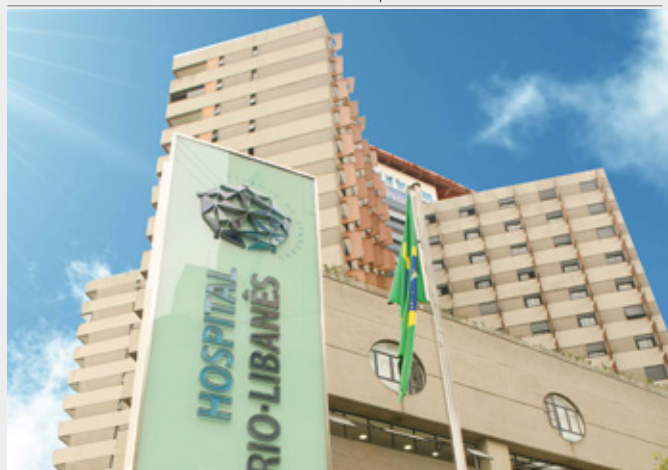

Hospital Sirio Libanes

Canada	Toronto, ON	Sick Kids Hospital* St. Michaels Hospital*
	Edmonton, AB	Grey Nuns Hospital*
	Vancouver, BC	Vancouver General Hospital*
	Oakville, ON	Oakville General Hospital*
	Kingston, ON	Hotel Dieu Hospital*
	Fort McMurray, AB	Northern Lights Health Ctr.*
	Montréal, QC	Hopital du Sacre Coeur de Montréal*
Colombia	Bogotá	Clínica Fundación Santa Fe* Clínica La Colina Bogotá*
	Ibagué	Clínica Los Nogales Ibagué*
Costa Rica	San Jose	Hospital San Juan de Dios*
	Siquirres	CENTRO DE ATENCION INTEGRAL DE SALUD DE SIQUIRRES*
Dominican Republic	Santo Domingo	CEDIMAT PROJECT*

Country	City	Name
Ecuador	Guayaquil	Omni Hospital, Guayaquil*
	Loja	Hospital Catacocha*
	Quito	Hospital de Los Valles*
El Salvador	San Salvador	HOSPITAL MATERNIDAD*
Guatemala	Guatemala City	Hospital de Villanueva*
	Chimaltengano	HOSPITAL CHIMALTENGANO*
	Coatepeque	HOSPITAL COATEPEQUE*
	Mazatenango	HOSPITAL DE MAZATENANGO*
Nicaragua	Managua	HOSPITAL METROPOLITANO VIVIAN PELLAS*
Panama	Panama City	Hospital UCI Adultos y Neomatos*
Peru	Lima	Clínica san Borja Internacional Clínica San Judas Tadeo
USA	New York, NY	NYU Hospital Center Helen L and Martin S Kimmel Pavilion *
	Seattle, WA	University of Washington Medical Center*
	Ann Arbor, MI	University of Michigan Medical Center*
	Nashville, TN	Vanderbilt University Medical Center*
	Philadelphia, PA	Hospital of the University of Pennsylvania*
Venezuela	Cagua	Centro Médico Cagua
	Caracas	Clinica Sanitas
	Caracas	Clinica La Urbina
	Pto. Cabello	Clinica San Jose
	San Cristóbal	Policlínica Táchira

*NFPA99

Some references for hospital equipment (Middle East, Africa)

Country	City	Name
Bahrain	Manama	BAHRAIN DEFENCE FORCE HOSPITAL
Egypt	Cairo	Dar El Fouad
		El Galaa Hospital
		Egypt Air hospital
		Al Salam international hospital
		Wadi Al Neel hospital
		Police Hospital Cairo
		Arab contractor Medical Center
		Dar Al Oyoun Hospital
		Asfour Charity Hospital
		Kobri El Koba Hospital
		Dar Al Fouad Hospital Nasr City*
As-Salam International Hospital*		
Al Azhar University*		
Mansoura	Mansoura University	
El Monofeya	El Araby International Hospital	
Alexandria	Police Hospital Alexandria	



Al Salam international hospital

Kuwait	KUWAIT CITY	SAFAT AMERICAN HOSPITAL
QATAR	DOHA	HAMAD BIN KHALIFA MEDICAL CITY
		HAMAD GENERAL HOSPITAL
		SIDRA MEDICAL AND RESEARCH CENTER
		HEART HOSPITAL
		AL RUMAILAH HOSPITAL
		FALCON CLINIC & HOSPITAL
		WAKRA HOSPITAL
		QATAR ORTHOPEDIC
DUKHAN	CUBAN HOSPITAL	



Aspetar

Country	City	Name
Saudi-Arabia	Dammam	Maternity and Children Hospital
	Al Khobar	King Fahd Teaching Hospital
	Makkah and Riyadh	King Faisal Hospital
	Najran	Inha University Hospital
		King Faisal Hospital*
	Riyadh	Prince Sultan Cardiac Center
		King Saud Bin Abdulaziz University Hospital
		Princess Noura University Hospital
		North Riyadh Hospital - 300 Bed*
		King Khaleed Hospital*
Prince Salman Hospital*		
Tabuk	Tabuk Military Hospital*	
Jeddah	King Fahd Hospital*	
UAE	ABU DHABI	ETIHAD AIRWAYS EMERGENCY RESPONSE CENTER
		GDC HOSPITAL
		AL NOOR HOSPITAL
		AL RAHBA HOSPITAL
		SHEIKH KHALIFA MEDICAL CITY
	AL AIN	AL AIN JIMI HOSPITAL
		TAWAM HOSPITAL
	Dubai	ZAHRA MEDICAL CENTER
		JALILA CHILDREN SPECIALTY HOSPITAL
	FUJAIRAH	FUJAIRAH HOSPITAL
SILAA	SILAA COMMUNITY HOSPITAL	



AL NOOR HOSPITAL

*NFPA99

Some references for hospital equipment (Asia Pacific, Asia)

Country	City	Name
China	Beijing	Beijing Hospital Peking Union Medical College Hospital Beijing Tongren Hospital Beijing Children's Hospital Beijing Anding Hospital Beijing Shijitan Hospital Peking University Sixth Hospital Beijing Jishuitan Hospital Peking University People's Hospital Peking University First Hospital Beijing Xuanwu Chinese PLA General Hospital The Seventh Medical Center of Chinese PLA General Hospital
	Shanghai	Shanghai Huashan Hospital Shanghai Changzheng Hospital Shanghai Sixth People's Hospital Shanghai Tenth People's Hospital Affiliated Huadong Hospital of Fudan University Affiliated Zhongshan Hospital of Fudan University Obstetrics & Gynecology Hospital of Fudan University The First Affiliated Hospital of Shanghai Jiaotong University School of Medicine Affiliated Tongren Hospital of Shanghai Jiaotong University School of Medicine Affiliated Renji Hospital of Shanghai Jiaotong University School of Medicine Affiliated Ruijin Hospital of Shanghai Jiaotong University School of Medicine



Beijing Union Medical College Hospital

Guangzhou	Guangzhou Center for Respiratory Medicine Guangdong Provincial People's Hospital Guangzhou First People's Hospital The First Affiliated Hospital Sun Yat-sen University SUN YAT-SEN Memorial Hospital The Third Affiliated Hospital of Guangzhou Medical University
Shijiazhuang	Hebei General Hospital Hebei Chest Hospital The Second Hospital of Hebei Medical University
Tianjing	Tianjin Medical University Cancer Institute & Hospital Tianjin First Central Hospital Tianjin Medical University General Hospital

Country	City	Name
China	Chongqing	Chongqing General Hospital The Second Affiliated Hospital of Chongqing Medical University The First Affiliated Hospital of Chongqing Medical University
	Nanjing	Nanjing Drum Tower Hospital
	Wuxi	Wuxi No.2 People's Hospital
	Huai'an	Hai'an Second People's Hospital
	Suzhou	The First Affiliated Hospital of Soochow Univ.
	Jinhua	Jinhua Municipal Central Hospital
	Shaoxing	Shaoxing Second Hospital
	Quzhou	Quzhou Central Hospital
	Hangzhou	The Second Affiliated Hospital of Zhejiang University School of Medicine Sir Run Run Shaw Hospital of Zhejiang University School of Medicine
	Anyang	Anyang People's Hospital
	Xinxiang	The First Affiliated Hospital of Xinxiang Medical University
	Zhengzhou	Henan Provincial People's Hospital Zhengzhou People's Hospital Henan Provincial Orthopedic Hospital The First Affiliated Hospital of Zhengzhou University



Chinese PLA General Hospital

Suining	Suining Central Hospital
Chengdu	Sichuan Provincial People's Hospital West China Hospital of Sichuan University The General Hospital of Sichuan Petroleum
Weifang	Weifang People's Hospital
Yantai	Yantai Yuhuangding Hospital
Linyi	Linyi People's Hospital
Jining	Jining No. 1 People's Hospital
Jinan	Shandong Provincial Hospital Affiliated to Shandong First Medical University Qilu Hospital of Shandong University
Qingdao	Qingdao Municipal Hospital The Affiliated Hospital of Qingdao University
Dalian	Affiliated Zhongshan Hospital of Dalian University

Country	City	Name
India	Bengaluru	Bhagwan Mahaveer Jain Hospital
	Bhubaneswar	Apollo Hospital
	Gurgaon	Medanta
	Jammu	Govt. Medical College & Hospital
	Kochi	Lourdes Hospital
	Lucknow	Ram Manohar Lohia
	Mumbai	Asian Heart Institute Harkishan Das Hospital
	Noida	Jaypee Hospital
	Thiruvananthapuram	Regional Cancer Center Hospital
	Thrissur	Govt. Medical College & Hospital
Indonesia	Aceh	RS. Umum Daerah Zaenal Abidin
	di Jogjakarta	Teaching Hospital Universitas Gadjah Mada
	Jakarta	Puri Indah Hospital Dr. Cipto Mangunkusumo Hospital National Brain Center Hospital Cawang Siloam MRCC Hospital Jakarta Heart Center Hospital
	Kalimantan	RS. Umum Daerah Wahab Syahrani
	Palembang	RS. Umum Moh. Husein
	Riau	Eka Hospital Interational Pakanbaru
	Serpong Tangerang	Eka Hospital
	Tangerang	Omni International Hospital Alam Sutera
	Siquirres	CENTRO DE ATENCION INTEGRAL DE SALUD DE SIQUIRRES



Gyeongsang National University Hospital

Malaysia	Kuala Lumpur	National Cancer Institute Putrajaya General Hospital of Kuala Lumpur
	Malacca	Melaka Straits Medical Centre
	Pahang	Hospital of Islamic International University
	Sabah	Gleneagles Kota Kinabalu
	Selangor	Medical Centre of Malaya University
Mongolia	Ulaanbaatar	International medical center LLC
Pakistan	Karachi	Sindh Institute of Urology and Transplant
	Karachi	Civil Hospital
Republic of Korea	Cheonan	Cheonan Medical Center
	Chuncheon	Kangwon National University Hospital
	Daejeon	Konyang University Hospital
	Incheon	Inha University Hospital

Country	City	Name		
Republic of Korea	Jeonju	Chonbuk National University Hospital		
	Seogwipo	Seogwipo Medical Center		
	Seoul	Seoul National University Hospital		
		Seoul Metropolitan Government Seoul National University Boramae Medical Center		
		The Catholic University of Korea Seoul St. Mary's Hospital Korea University Medical Center National Medical Center National Police Hospital Korea Institute of Radiological & Medical Sciences		
Wonju	Severance Hospital			
Singapore	Singapore	Novena Mount Elisabeth Hospital Khoo Teck Puat Hospital NUH Medical Centre Singapore General Hospital Ng Teng Fong Hospital NUH Hospital		
		Taiwan	Taichung	China Medical University Hospital
		Tainan	National Cheng Kung University Hospital	
		Taipei	Mackay Memorial Hospital Tri-Service General Hospital	
Thailand	Bangkok	Siriraj Hospital, Mahidol University Bangkok Hospital Bumrungrad Hospital Vichaiyut Hospital St. Louis Hospital Sukumvit Hospital Huachiw Hospital Veterans General Hospital Paolo Memorial Sapankaew		
		Chiangmai	Bangkok Hospital	
		Lampang	Lampang Hospital	
		Phitsanulok	Bangkok Hospital	



Bangkok Hospital

Vietnam	An Giang Province	An Giang General Hospital
	Binh Duong	My Phuoc General Hospital
	Binh Duong Province	Hanh Phuc Hospital
	Can Tho City	Can Tho General Hospital
	Da Nang	Family Hospital
	Ha Noi	High Tech Center - Viet Duc Hospital
	HCMC	Hoa Lam Shangrila Hospital Fortis Hoan My Phan Xich Long Hospital
	Hue	Phong Dien General Hospital

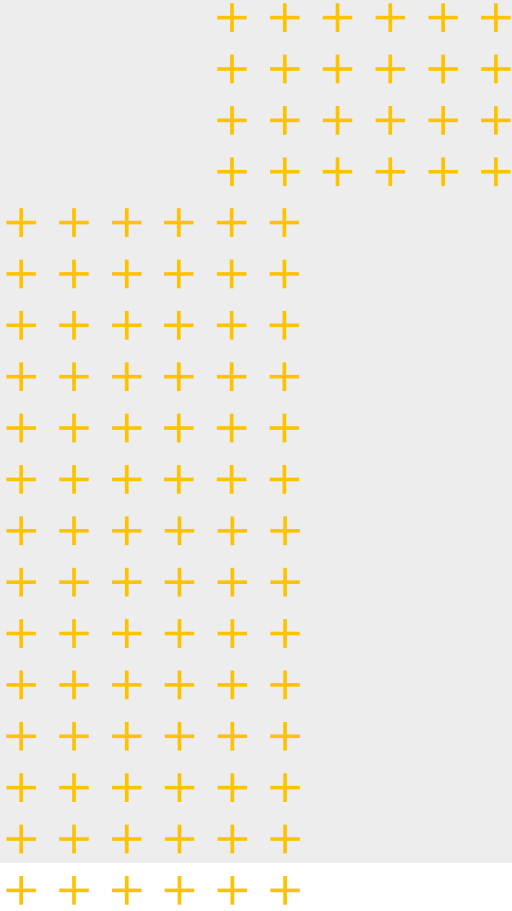

Bender GmbH & Co. KG

Londorfer Straße 65
35305 Grünberg
Germany

Tel.: +49 6401 807-0
info@bender.de
www.bender.de/en

Photos: Fotolia (© jenshagen), Adobe Stock (© akesin, © spotmatikphoto, © Sweet, © horsemen, © Ruan Jordaan/peopleimages.com, © Gorodenkoff Productions OU, © Jose Luis Stephens, © koldunova, © totojang1977, © kbarzycki, © Nancy Pauwels, © TeacherPhoto, © Southworks, © 2ragon, © agnormark, © malp.), 123RF (© stefan77) and Bender archives.

2113en / 02.2024 / © Bender GmbH & Co. KG, Germany
Subject to change! The specified standards take into account the version valid at the time of printing.

